

General Purpose Relays

Plug-in Relays Application and Features (CR420)10-2
 Plug-in Relays Product Series Overview (CR420).....10-3
 Plug-in Relays Product Tables (CR420H and CR420J).....10-4
 Plug-in Relays Product Tables (CR420K and CR420M).....10-5
 Plug-in Relays Product Tables (CR420N).....10-6
 Plug-in Relays Technical Data (CR420H and CR420J).....10-7
 Plug-in Relays Technical Data (CR420K and CR420M).....10-8
 Plug-in Relays Technical Data (CR420N).....10-9
 Plug-in Relays Connection Diagrams (CR420).....10-10
 Plug-in Relays Outlines and Dimensions (CR420).....10-11

Industrial/Machine Tool Relays

AC Operated, DC Operated, Latched Relays
 Application and Features (CR120B)10-14
 AC Operated, DC Operated, Latched Relays Product Tables
 (CR120B, CR120BD, CR120BL)10-15
 AC Operated Weld Check Relays Description (CR120BP)...10-16
 AC Operated Weld Check Relays
 Product Tables (CR120BP).....10-17
 Standard Components (CR120B)10-18
 Accessories (CR120B)10-19
 Outlines and Dimensions (CR120B)10-20

IEC Electronic Timers

IEC Electronic Timers Product Overview10-22
 Multivoltage Electronic Timers Product Tables.....10-23
 Multivoltage Electronic Timers Technical Data.....10-25
 Multivoltage Electronic Timers
 Outlines and Dimensions10-32

IEC Protective Relays

IEC Protective Relays Overview10-33
 Liquid Level Detector Relays Product Tables.....10-34
 Control and Protection Relays Product Tables.....10-35
 IEC Protective Relays Technical Data10-36
 IEC Protective Relays Outlines and Dimensions10-44



Logic Control General Purpose Relays

CR420

Plug-In Relays

Section 10

Application

The CR420 general purpose plug-in relays are commonly used for low cost switching in many industrial control circuits. Typical applications include industrial equipment, machine tool, HVAC, lighting, vending, commercial appliances, elevators, and spa controls.

These relays and sockets are powerful and highly cost effective. Versions are available with AC and DC coils, plug-in or direct flange mounting, and multiple contact configurations.

Features

- Cost Effective: Competitive every day prices make these relays an excellent solution for low voltage industrial switching.
- Powerful: From 5 Amp (4 pole) to 30 Amp (1 pole), these relays handle large loads in a compact package.
- Reliable Operation: 100% tested, ensuring performance the first time. The long electrical life will give confidence and satisfied customers.
- Mechanical Indicator/Manual Operator: Helps field service personnel test control circuits.
- LED Indicating Lamp: Easily show coil status under low light conditions.
- IP20 Finger-Safe Sockets: Protects users from screws during termination.

Product Number Selection Instructions

1. Specify a complete product number by including coil suffix in place of *, see coil suffix table for coil codes. Please consult factory if desired product configuration does not appear.

Reference Publications

Pricing and Selection Guide

DEP-115



CR420K General Purpose Plug-In Relays

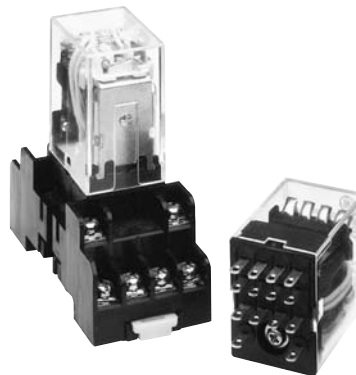





CR420M General Purpose Plug-In Relays



Logic Control General Purpose Relays CR420 Plug-In Relays

General Purpose Plug-in Relays at a Glance

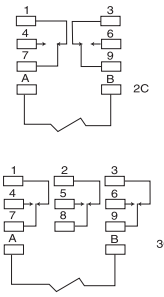
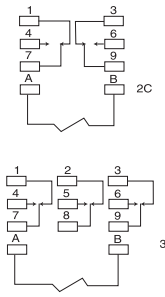
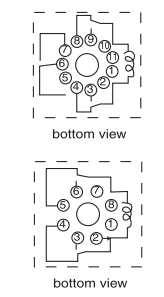
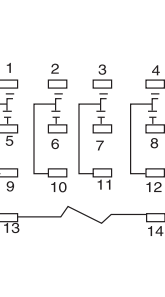
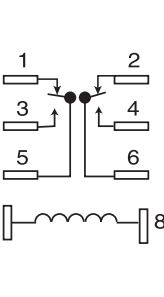
Product Series	CR420H	CR420J	CR420K	CR420M	CR420N
					
Connection diagram					
Approval & Standards	UL, CSA, CE	UL, CSA, CE	UL, CSA, CE	UL, CSA, CE	UL, CSA, CE
Contact Arrangements	SPDT (DB-DM), DPDT, 3PDT	3PDT	DPDT, 3PDT	4PDT	SPDT, DPDT, 4PDT
Contact Material	AgCdO	Ag Alloy	Ag	Ag	AgCdO
Maximum Contact Ratings	SPDT-30A @ 240VAC DPDT-25A @ 240VAC 3PDT-20A @ 240VAC	DPDT-13A @ 240VAC 3PDT-13A @ 240VAC	SPDT-10A @ 240VAC, 28 VDC 1/3 HP @ 120VAC 1/2 HP @ 240VAC	5A @ 240VAC, 28 VDC 1/10 HP @ 120/24VAC	SPDT-15A @ 240VAC DPDT-10A @ 240VAC 4PDT-10A @ 240VAC
Mechanical Life	10,000,000 operations	10,000,000 operations	10,000,000 operations	10,000,000 operations	10,000,000 operations
Electrical Life at Rated Load	100,000 operations	100,000 operations	100,000 operations	100,000 operations	100,000 operations
Nominal Coil Voltage	6-240VAC, 12-110 VDC	6-240VAC, 24-125 VDC	6-240VAC, 12-110 VDC	6-240VAC, 12-110 VDC	6-240VAC, 12-110 VDC
Mounting Type	Socket, Flange, PCB	Socket, Side Flange	Socket	Socket, Flange, PCB	Socket, Flange, PCB
Indicating Options	Manual Operator and/or LED indicator	None	Manual Operator and/or LED indicator	Manual Operator and/or LED indicator	Manual Operator and/or LED indicator



Logic Control General Purpose Relays

Section 10

CR420

Plug-In Relays

SPDT, 30A, 240 VAC

DPDT, 25A, 240 VAC

3PDT, 20A, 240 VAC

DPDT, 13A, 240 VAC

3PDT, 13A, 240 VAC

CR420H

No. of Poles	Contacts	Contact Rating	Mounting type	Indicating Options	Product Number	List Price GO-10PR
1	SPDT (DM/DB)	30A	Side Flange	None	CR420HFAZ11*	\$17.00
1	SPDT (DM/DB)	30A	Top Flange	None	CR420HTAZ11*	\$18.00
2	DPDT	25A	Side Flange	None	CR420HFA022*	\$13.00
2	DPDT	20A	Socket	None	CR420HFA022*	\$13.00
2	DPDT	25A	Socket	Push to test & LED	CR420HPC022*	\$17.00
2	DPDT	25A	Socket	LED Indicator	CR420HPL022*	\$15.00
3	3PDT	20A	Side Flange	None	CR420HFA033*	\$15.00
3	3PDT	25A	Socket	None	CR420HFA033*	\$15.00
3	3PDT	20A	Socket	Push to test & LED	CR420HPC033*	\$19.00
3	3PDT	20A	Socket	LED Indicator	CR420HPL033*	\$17.00
3	3PDT	20A	Top Flange	None	CR420HTA033*	\$16.00

Specify a complete product number by including coil suffix in place of *, see Coil Suffix Table below for coil codes.
Please consult factory, if desired product configuration does not appear.



Coil Suffix Table

AC	6V	12V	24V	120V	240V
	A	B	C	J	N
DC	12V	24V	48V	110V	125V
	2	4	7	9	5

Accessories

Description	Product Number	List Price GO-10PR
Socket for Panel/DIN Rail Mount	CR420HA	\$7.00
Hold-down Clip ¹	CR420HAS	\$2.25

Contact factory regarding versions not shown here.

¹Quantity is 1 per product number; order 1 per socket. Quantity and selection based on socket, not on relay.

CR420J

No. of Poles	Contacts	Contact Rating	Mounting type	Indicating Options	Product Number	List Price GO-10PR
2	DPDT	13A	Side Flange	None	CR420JFA022*	\$11.00
2	DPDT	13A	Socket	None	CR420JPA022*	\$11.00
2	DPDT	13A	Socket	Push to test & LED	CR420JPC022*	\$15.00
2	DPDT	13A	Socket	LED Indicator	CR420JPL022*	\$13.00
2	DPDT	13A	Top Flange	None	CR420JTA022*	\$11.00
3	3PDT	13A	Side Flange	None	CR420JFA033*	\$13.00
3	3PDT	13A	Socket	None	CR420JPA033*	\$13.00
3	3PDT	13A	Socket	Push to test & LED	CR420JPC033*	\$17.00
3	3PDT	13A	Socket	LED Indicator	CR420JPL033*	\$15.00
3	3PDT	13A	Top Flange	None	CR420JTA033*	\$13.00

Specify a complete product number by including coil suffix in place of *, see Coil Suffix Table below for coil codes.
Please consult factory, if desired product configuration does not appear.



Coil Suffix Table

AC	6V	12V	24V	120V	240V
	A	B	C	J	N
DC	12V	24V	48V	110V	125V
	2	4	7	9	5

Accessories

Description	Product Number	List Price GO-10PR
Socket for Panel/DIN Rail Mount	CR420HA	\$7.00
Hold-down Clip ¹	CR420HAS	\$2.25

Contact factory regarding versions not shown here.

¹Quantity is 1 per product number; order 1 per socket. Quantity and selection based on socket, not on relay.



Product Number Selection Instructions: See page 10-2

Logic Control General Purpose Relays

CR420

Plug-In Relays

DPDT, 10A, 240 VAC

3PDT, 10A, 240 VAC

DPDT, 5A, 240 VAC

4PDT, 5A, 240 VAC

CR420K

No. of Poles	Contacts	Contact Rating	Mounting type	Indicating Options	Product Number	List Price GO-10PR
2	DPDT	10A	Socket	Push to test & LED	CR420KPC022*	\$12.00
2	DPDT	10A	Socket	Push to Test	CR420KPM022*	\$10.00
3	3PDT	10A	Socket	Push to test & LED	CR420KPC033*	\$16.00
3	3PDT	10A	Socket	Push to Test	CR420KPM033*	\$14.00

Specify a complete product number by including coil suffix in place of *, see Coil Suffix Table below for coil codes.
Please consult factory, if desired product configuration does not appear.



Coil Suffix Table

AC	6V	12V	24V	120V	240V
	A	B	C	J	N
DC	12V	24V	48V	110V	125V
	2	4	7	9	5

Accessories

Description	Product Number	List Price GO-10PR
Socket for Panel/DIN Rail Mount (DPDT)	CR420KA2	\$5.00
Socket for Panel/DIN Rail Mount (3PDT)	CR420KA3	\$7.00
Socket for Panel/DIN Rail Mount (DPDT)	CR420KA21	\$8.00
Socket for Panel/DIN Rail Mount (3PDT)	CR420KA31	\$10.00
Hold-down Clips ²	CR420KAS	\$2.25

Contact factory regarding versions not shown here.

²Quantity is 2 per product number; order 1 CR420KAS per socket. Quantity and selection based on socket, not on relay.

CR420M

No. of Poles	Contacts	Contact Rating	Mounting type	Indicating Options	Product Number	List Price GO-10PR
2	DPDT	5A	Socket	None	CR420MPA022*	\$8.00
2	DPDT	5A	Socket	Push to test & LED	CR420MPC022*	\$14.00
2	DPDT	5A	Socket	LED Indicator	CR420MPL022*	\$10.00
4	4PDT	5A	Socket	None	CR420MPA044*	\$10.00
4	4PDT	5A	Socket	Push to test & LED	CR420MPC044*	\$14.00
4	4PDT	5A	Socket	LED Indicator	CR420MPL044*	\$12.00
4	4PDT	3A ¹	Socket	LED Indicator	CR420MPLG44*	\$17.00

Specify a complete product number by including coil suffix in place of *, see Coil Suffix Table below for coil codes.
Please consult factory, if desired product configuration does not appear.

¹Au diffused contact suitable for low level switching.



Coil Suffix Table

AC	6V	12V	24V	120V	240V
	A	B	C	J	N
DC	12V	24V	48V	110V	125V
	2	4	7	9	5

Accessories

Description	Product Number	List Price GO-10PR
Socket for Panel/DIN Rail Mount	CR420MA	\$8.00
Hold-down Clips ²	CR420MAS	\$2.25

Contact factory regarding versions not shown here.

²Quantity is 2 per product number; order 1 CR420MAS per socket. Quantity and selection based on socket, not on relay.



Logic Control General Purpose Relays

Section 10

CR420

Plug-In Relays

SPDT, 15A, 240 VAC

DPDT, 10A, 240 VAC

4PDT, 10A, 240 VAC

CR420N

No. of Poles	Contacts	Contact Rating	Mounting type	Indicating Options	Product Number	List Price GO-10PR
1	SPDT	15A	Socket	None	CR420NPA011*	\$11.00
1	SPDT	10A	Socket	Push to test & LED	CR420NPC011*	\$15.00
1	SPDT	10A	Socket	LED Indicator	CR420NPL011*	\$13.00
1	SPDT	15A	Top Flange	None	CR420NTA011*	\$11.00
2	DPDT	10A	Socket	None	CR420NPA022*	\$11.00
2	DPDT	10A	Socket	Push to test & LED	CR420NPC022*	\$15.00
2	DPDT	15A	Socket	LED Indicator	CR420NPL022*	\$13.00
2	DPDT	10A	Top Flange	None	CR420NTA022*	\$11.00
4	4PDT	10A	Socket	None	CR420NPA044*	\$13.00
4	4PDT	10A	Socket	Push to test & LED	CR420NPC044*	\$17.00
4	4PDT	10A	Socket	LED Indicator	CR420NPL044*	\$15.00
4	4PDT	10A	Top Flange	None	CR420NTA044*	\$13.00

Specify a complete product number by including coil suffix in place of *, see Coil Suffix Table below for coil codes.
Please consult factory, if desired product configuration does not appear.



Coil Suffix Table

AC	6V	12V	24V	120V	240V
	A	B	C	J	N
DC	12V	24V	48V	110V	125V
	2	4	7	9	5

Accessories

Description	Product Number	List Price GO-10PR
Socket for Panel/DIN Rail Mount	CR420NA2	\$7.00
Socket for Panel/DIN Rail Mount	CR420NA4	\$10.00
Socket for Panel/DIN Rail Mount	CR420NA21	\$8.00
Hold-down Clip ¹	CR420NAS	\$2.25
Hold-down Clips ²	CR420MAS	\$2.25

Contact factory regarding versions not shown here.

¹Fits CR420NA2 and NA21 sockets only. Quantity is 1 per product number; order 1 per socket. Quantity and selection is based on socket, not on relay.

²Fits CR420NA4 socket. Quantity is 2 per product number; order 1 CR420MAS per socket. Quantity and selection is based on socket, not on relay.



Product Number Selection Instructions: See page 10-2

Logic Control General Purpose Relays

CR420

Plug-In Relays
Technical Data

Section 10

CR420H Contact Data

Contact Ratings	SPDT (DM/DB):	30A @ 240VAC, 28VDC 1 HP @ 120VAC 1 1/2 HP @ 240VAC
	DPDT:	25A @ 240VAC, 28VDC 3/4 HP @ 120VAC 1 HP @ 240VAC
	3PDT:	20A @ 240VAC, 28VDC 3/4 HP @ 120VAC 1 HP @ 240VAC
Contact Material	Ag Alloy	
Maximum Contact Voltage	220VAC, 110VDC	
Carry Current	10A	
Electrical Life	100,000 operations	
Mechanical Life	10,000,000 operations	
Minimum Permissible Load	0.5A @ 1VDC	

CR420H Coil Data @ 20°C

AC Coil Power Consumption	2.3VA @ 50/60 Hz
DC Coil Power Consumption	1.5W
Coil Pick-Up Voltage	80% Nominal Maximum
AC Coil Drop-Out Voltage	30% Nominal Minimum
DC Coil Drop-Out Voltage	10% Nominal Minimum
Maximum Coil Voltage	110% Nominal Maximum

CR420H General Technical Information

Contact Resistance	50m ohms Maximum
Operating Time	25mS Maximum
Release Time	25mS Maximum
Insulation Resistance	100m ohms Minimum @ 500 VDC
Electrical Switching Rate	30 Operations/Minute
Mechanical Switching Rate	240 Operations/Minute
Dielectric Strength Between Coil & Contacts	1500VAC for One Minute
Dielectric Strength Between Contacts	750VAC for One Minute
Mechanical Vibration	100G Minimum
Malfunction Vibration	10G Minimum
Operating Temperature	-10° to 60°C
Humidity	35-85% RH
Weight	Approx. 85 g

CR420J Contact Data

Contact Ratings	13A @ 240VAC
Contact Material	Ag Alloy
Maximum Contact Voltage	24 VDC 24VAC 120 VAC
Carry Current	10A
Electrical Life	100,000 operations
Mechanical Life	10,000,000 operations
Minimum Permissible Load	0.5A @ 5VDC

CR420J Coil Data @ 20°C

AC Coil Power Consumption	2.3VA @ 50/60 Hz
DC Coil Power Consumption	
Coil Pick-Up Voltage	AC 85% Nominal Maximum DC 75% Nominal Maximum
AC Coil Drop-Out Voltage	30% Nominal Minimum
DC Coil Drop-Out Voltage	10% Nominal Minimum
Maximum Coil Voltage	110% Nominal Maximum

CR420J General Technical Information

Contact Resistance	100m ohms Maximum
Operating Time	25mS Maximum
Release Time	25mS Maximum
Insulation Resistance	1,000 Mohm
Electrical Switching Rate	30 Operations/Minute
Mechanical Switching Rate	240 Operations/Minute
Dielectric Strength Between Coil & Contacts	1500VAC for One Minute
Dielectric Strength Between Contacts	750VAC for One Minute
Mechanical Vibration	100G Minimum
Malfunction Vibration	20G Minimum
Operating Temperature	-25° to 60°C
Humidity	35-85% RH
Weight	Approx. 85 g



Logic Control General Purpose Relays

Section 10

CR420

Plug-In Relays
Technical Data

CR420K Contact Data

Contact Ratings	DPDT/3PDT: 10A res. @ 240VAC, 24VDC 7A Ind. (p.f.=0.4), 250VAC 1/2 HP @ 120VAC, 1/3 HP @ 240VAC
Contact Material	Ag Alloy
Maximum Contact Voltage	220VAC, 110VDC
Carry Current	10A
Electrical Life	100,000 operations
Mechanical Life	10,000,000 operations
Minimum Permissible Load	100mA @ 5VDC

CR420M Contact Data

Contact Ratings	4PDT: 5A @ 240VAC, 24VDC 1/10 HP @ 120/240VAC
Contact Material	Ag Alloy
Maximum Contact Voltage	220VAC, 110VDC
Carry Current	5A
Electrical Life	100,000 operations
Mechanical Life	10,000,000 operations
Minimum Permissible Load	SPDT/4PDT: 4PDT (Ag with AU diffused): 10mA @ 10VDC 1mA @ 10VDC

CR420K Coil Data @ 20°C

AC Coil Power Consumption	2.3VA @ 50/60 Hz
DC Coil Power Consumption	1.5W
Coil Pick-Up Voltage	80% Nominal Maximum
AC Coil Drop-Out Voltage	30% Nominal Minimum
DC Coil Drop-Out Voltage	10% Nominal Minimum
Maximum Coil Voltage	110% Nominal Maximum

CR420M Coil Data @ 20°C

AC Coil Power Consumption	1.1VA @ 50/60 Hz
DC Coil Power Consumption	0.9W
Coil Pick-Up Voltage	AC 85% Nominal Maximum DC 75% Nominal Maximum
AC Coil Drop-Out Voltage	30% Nominal Minimum
DC Coil Drop-Out Voltage	10% Nominal Minimum
Maximum Coil Voltage	110% Nominal Maximum

CR420K General Technical Information

Contact Resistance	100m ohms Maximum
Operating Time	25mS Maximum
Release Time	25mS Maximum
Insulation Resistance	100m ohms Minimum @ 500VDC
Electrical Switching Rate	30 Operations/Minute
Mechanical Switching Rate	240 Operations/Minute
Dielectric Strength Between Coil & Contacts	1500VAC @ 50/60 Hz
Dielectric Strength Between Contacts	1000VAC @ 50/60 Hz
Mechanical Vibration	100G Minimum
Malfunction Vibration	10G Minimum
Operating Temperature	-10° to 40°C
Humidity	35-85% RH
Weight	Approx. 85 g

CR420M General Technical Information

Contact Resistance	100m ohms Maximum
Operating Time	25mS Maximum
Release Time	25mS Maximum
Insulation Resistance	100m ohms Minimum @ 500VDC
Electrical Switching Rate	30 Operations/Minute
Mechanical Switching Rate	240 Operations/Minute
Dielectric Strength Between Coil & Contacts	1500VAC @ 50/60 Hz
Dielectric Strength Between Contacts	1000VAC @ 50/60 Hz
Mechanical Vibration	100G Minimum
Malfunction Vibration	10G Minimum
Operating Temperature	-25° to 70°C
Humidity	35-85% RH
Weight	Approx. 35 g



Product Number Selection Instructions: See page 10-2

Logic Control General Purpose Relays CR420 Plug-In Relays Technical Data

CR420N Contact Data

Contact Ratings	SPDT:	Resistive (p.f.=1.0) 15A@240VAC, 24VDC Inductive (p.f.=0.4) 7A@240VAC, 24VDC 1/3 HP @ 120VAC, 1/2 HP @ 240VAC
	DPDT/4PDT:	Resistive (p.f.=1.0) 10A@240VAC, 24VDC Inductive (p.f.=0.4) 5A@240VAC, 24VDC 1/3 HP @ 120VAC, 1/2 HP @ 240VAC
Contact Material	AgCdO	
Maximum Contact Voltage	240VAC, 110VDC	
Carry Current	10A	
Electrical Life	100,000 operations	
Mechanical Life	10,000,000 operations	
Minimum Permissible Load	10mA @ 5VDC	

CR420N Coil Data @ 20°C

AC Coil Power Consumption	1.1VA @ 50/60 Hz
DC Coil Power Consumption	0.9W
Coil Pick-Up Voltage	AC 85% Nominal Maximum DC 75% Nominal Maximum
AC Coil Drop-Out Voltage	30% Nominal Minimum
DC Coil Drop-Out Voltage	10% Nominal Minimum
Maximum Coil Voltage	110% Nominal Maximum

CR420N General Technical Information

Contact Resistance	100m ohms Maximum	
Operating Time	25mS Maximum	
Release Time	25mS Maximum	
Insulation Resistance	100m ohms Minimum @ 500VDC	
Electrical Switching Rate	30 Operations/Minute	
Mechanical Switching Rate	240 Operations/Minute	
Dielectric Strength Between Coil & Contacts	1500VAC for One Minute	
Dielectric Strength Between Contacts	1000VAC for One Minute	
Mechanical Vibration	100G Minimum	
Malfunction Vibration	10G Minimum	
Operating Temperature	-25° to 60°C	
Humidity	35-85% RH	
Weight	SPDT/DPDT: 4PDT:	Approx. 35 g Approx. 85 g



Logic Control General Purpose Relays

Section 10

CR420

Plug-In Relays

Connection Diagrams

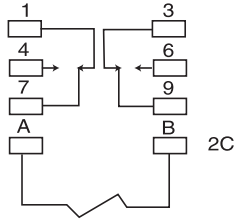

CR420H-DPDT

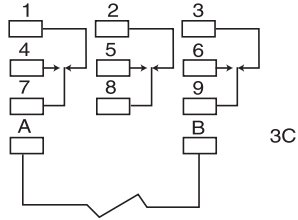

CR420H-3PDT

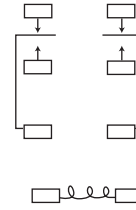

CR420H-SPDT DM/DB

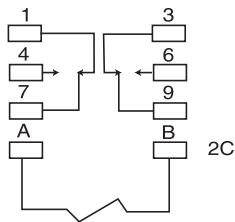

CR420J-DPDT

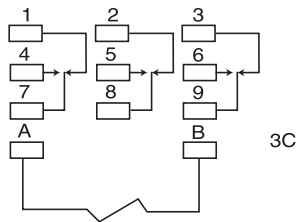

CR420J-3PDT

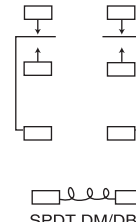

CR420J-SPDT DM/DB

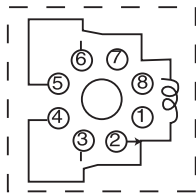

bottom view

CR420K-DPDT

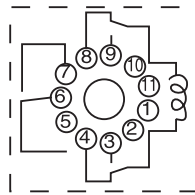

bottom view

CR420K-3PDT

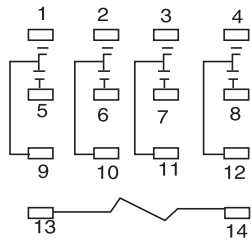

CR420M-4PDT

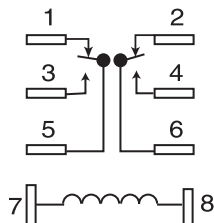

CR420N-DPDT

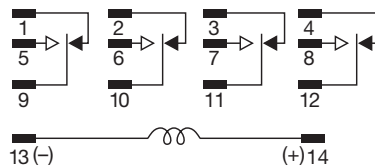

CR420N-4PDT



Product Number Selection Instructions: See page 10-2

Logic Control General Purpose Relays

CR420

Plug-In Relays

Outlines and Dimensions

Section 10

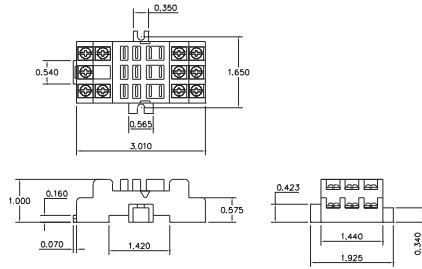

CR420HA Socket

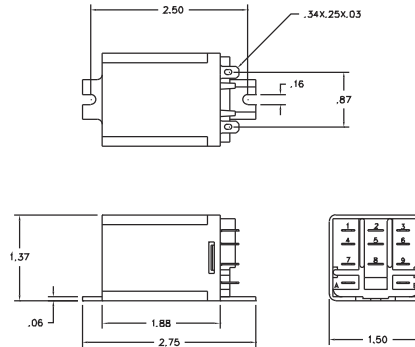

CR420HF

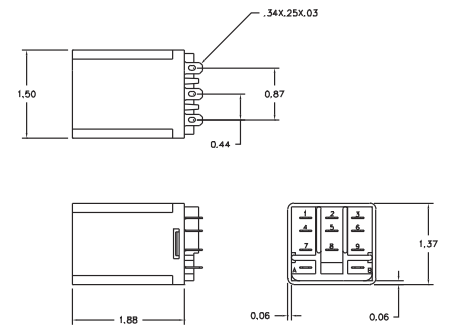

CR420HP

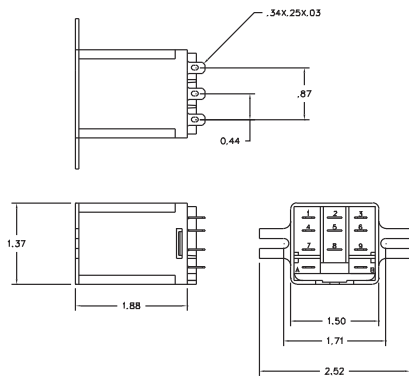

CR420HT

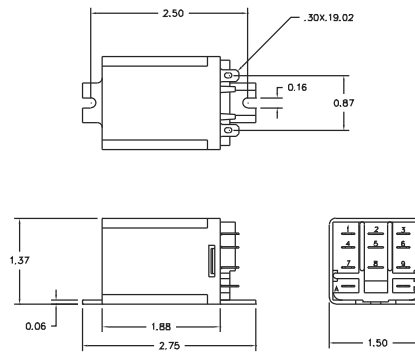

CR420JF

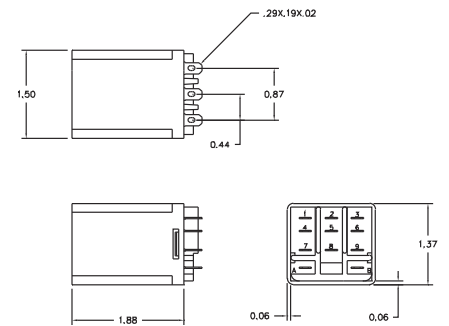

CR420JP

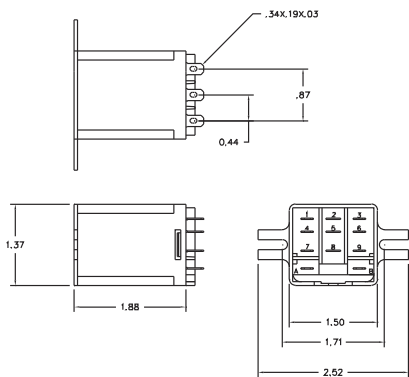

CR420JT

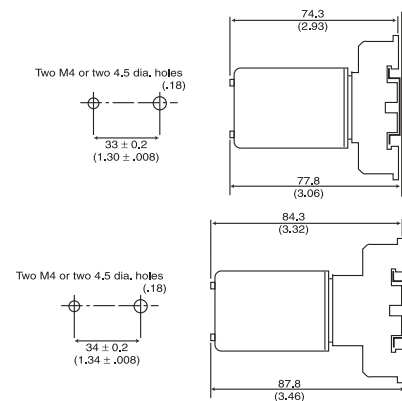

CR420K

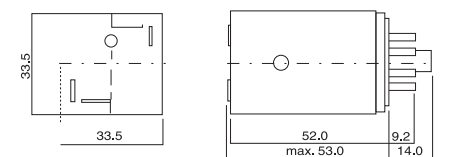

CR420K



Logic Control General Purpose Relays CR420

Plug-In Relays
Outlines and Dimensions

Section 10

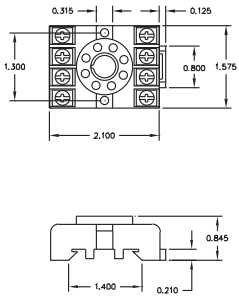

CR420KA2 Socket

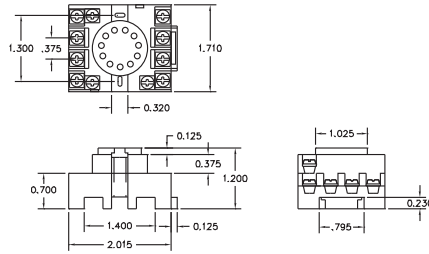

CR420KA3 Socket

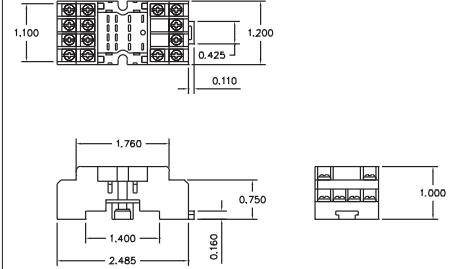

CR420MA Socket

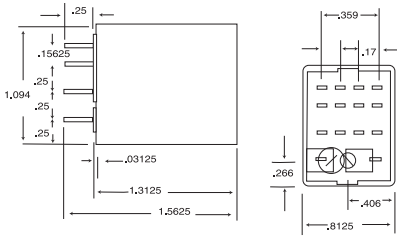

CR420MP

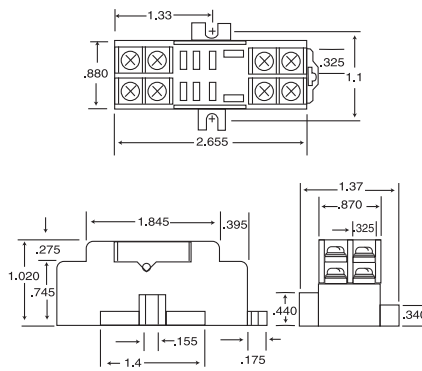

CR420NA2 Socket

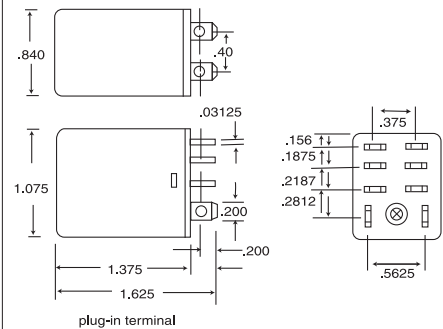

CR420N SPDT/DPDT

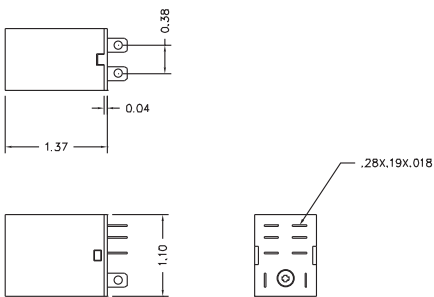

CR420NT SPDT/DPDT

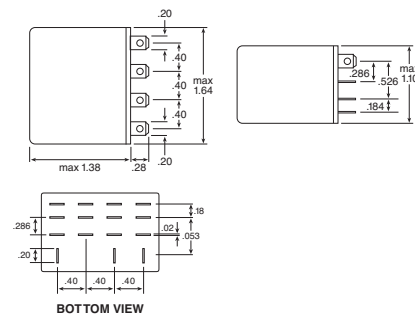

CR420NP 4PDT



Product Number Selection Instructions: See page 10-2

Logic Control General Purpose Relays

CR420

Plug-In Relays

Outlines and Dimensions

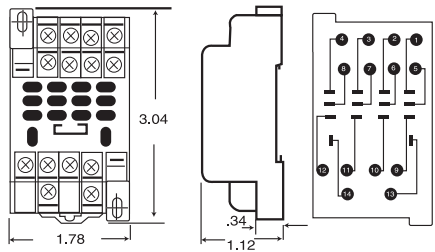

CR420NA4 Socket

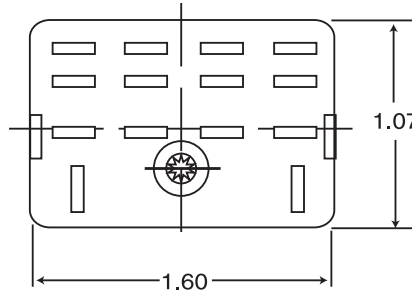

CR420NT 4PDT

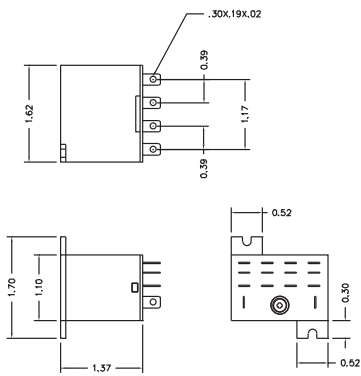

CR420NTA044

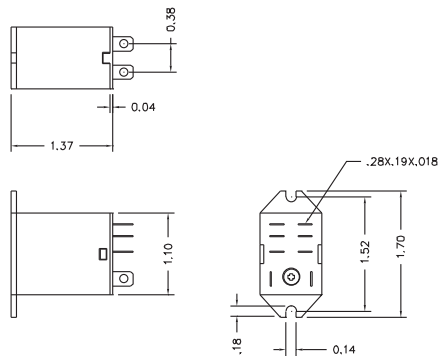

CR420NTA011



Logic Control Industrial/Machine Tool Relays

Section 10

CR120B

600 V
10 Amperes Continuous
60 Hz

Application

The CR120B and CR120BL Series A, multi-circuit industrial relays are designed to meet most panel application requirements. They are available as standard or latched relays.

Industrial relays may be ordered as complete devices from the pricing tables with the NO and NC pole combination desired. The relay components may also be purchased separately and assembled in standard or latched forms (see Standard Components, page 10-18).

All forms of the relay mount on the same base, and in the same small panel-mounting area. Relays may be arranged in any configuration, or modified on a panel without altering the mounting area.

Features

- Bifurcated contacts assure positive make: unique bifurcated contacts assure positive make at all voltages and give excellent fidelity even in harsh environments.
- Transparent Lexan®: contact cartridges allows inspection of contacts.
- Convertible contacts: allows conversion from normally open to normally closed, or vice versa. Just change the terminal screws and invert the contact module.
- Quick-change coil: can be changed without removing any screws.

Product Number Selection Instructions

1. Specify by complete product number, including coil suffix in place of ** or ††.
Example: For a six-pole relay with four-NO and two-NC poles, a coil operating on 120 Volts, 60 Hertz, order CR120B04202 (complete relay), at **\$132.00, GO-10G4**. Or order the following components for customer mounting: CR120B00002 (base relay assembly), at **\$48.00, GO-10G4**; CR120BX3 (adder deck), at **\$12.00, GO-10G4**; and five CR120BX1 (contacts), at **\$12.00 (each), GO-10G4**.
2. NEMA Type 1 enclosures are available for CR120B relays.
For pricing, see page 10-19.

Reference Publications

AC Relays Instructions	GEH-4115
Latch Relays Instructions	GEH-4120

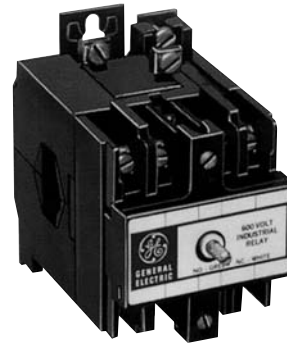

CR120B Standard AC Relay

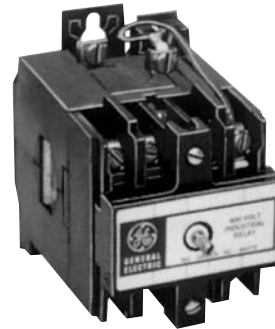

CR120BD Standard DC Relay



CR120BL Latched Relay



Logic Control Industrial/Machine Tool Relays

CR120B, CR120BD, CR120BL

AC Operated Relays/DC Operated Relays/AC Operated Latch Relays

CR120B AC Operated Relays

No. of Poles	Contact Configuration	Product Number	List Price GO-10G4
2	0 NO 2 NC	CR120B002**	\$84.00
2	1 NO 1 NC	CR120B011**	\$84.00
2	2 NO 0 NC	CR120B020**	\$72.00
3	0 NO 3 NC	CR120B003**	\$96.00
3	1 NO 2 NC	CR120B012**	\$96.00
3	2 NO 1 NC	CR120B021**	\$96.00
3	3 NO 0 NC	CR120B030**	\$84.00
4	0 NO 4 NC	CR120B004**	\$108.00
4	1 NO 3 NC	CR120B013**	\$108.00
4	2 NO 2 NC	CR120B022**	\$108.00
4	3 NO 1 NC	CR120B031**	\$108.00
4	4 NO 0 NC	CR120B040**	\$96.00
6	0 NO 6 NC	CR120B006**	\$132.00
6	1 NO 5 NC	CR120B015**	\$132.00
6	2 NO 4 NC	CR120B024**	\$132.00
6	3 NO 3 NC	CR120B033**	\$132.00
6	4 NO 2 NC	CR120B042**	\$132.00
6	5 NO 1 NC	CR120B051**	\$132.00
6	6 NO 0 NC	CR120B060**	\$120.00
8	0 NO 8 NC	CR120B008**	\$156.00
8	1 NO 7 NC	CR120B017**	\$156.00
8	2 NO 6 NC	CR120B026**	\$156.00
8	3 NO 5 NC	CR120B035**	\$156.00
8	4 NO 4 NC	CR120B044**	\$156.00
8	5 NO 3 NC	CR120B053**	\$156.00
8	6 NO 2 NC	CR120B062**	\$156.00
8	7 NO 1 NC	CR120B071**	\$156.00
8	8 NO 0 NC	CR120B080**	\$144.00
10	2 NO 8 NC	CR120B028**	\$180.00
10	4 NO 6 NC	CR120B046**	\$180.00
10	6 NO 4 NC	CR120B064**	\$180.00
10	8 NO 2 NC	CR120B082**	\$180.00
10	10 NO 0 NC	CR120B100**	\$168.00
12	4 NO 8 NC	CR120B048**	\$204.00
12	6 NO 6 NC	CR120B066**	\$204.00
12	8 NO 4 NC	CR120B084**	\$204.00
12	10 NO 2 NC	CR120B102**	\$204.00
12	12 NO 0 NC	CR120B120**	\$192.00

**Insert coil number from appropriate suffix table to complete product number.

CR120BL AC Operated Latched Relay

No. of Poles	Contact Configuration	Product Number	List Price GO-10G4
2	0 NO 2 NC	CR120BL002**	\$185.00
2	1 NO 1 NC	CR120BL011**	\$185.00
2	2 NO 0 NC	CR120BL020**	\$172.00
3	0 NO 3 NC	CR120BL003**	\$198.00
3	1 NO 2 NC	CR120BL012**	\$198.00
3	2 NO 1 NC	CR120BL021**	\$198.00
3	3 NO 0 NC	CR120BL030**	\$185.00
4	0 NO 4 NC	CR120BL004**	\$211.00
4	1 NO 3 NC	CR120BL013**	\$211.00
4	2 NO 2 NC	CR120BL022**	\$211.00
4	3 NO 1 NC	CR120BL031**	\$211.00
4	4 NO 0 NC	CR120BL040**	\$198.00
6	0 NO 6 NC	CR120BL006**	\$238.00
6	1 NO 5 NC	CR120BL015**	\$238.00
6	2 NO 4 NC	CR120BL024**	\$238.00
6	3 NO 3 NC	CR120BL033**	\$238.00
6	4 NO 2 NC	CR120BL042**	\$238.00
6	5 NO 1 NC	CR120BL051**	\$238.00
6	6 NO 0 NC	CR120BL060**	\$224.00
8	0 NO 8 NC	CR120BL008**	\$264.00
8	1 NO 7 NC	CR120BL017**	\$264.00
8	2 NO 6 NC	CR120BL026**	\$264.00
8	3 NO 5 NC	CR120BL035**	\$264.00
8	4 NO 4 NC	CR120BL044**	\$264.00
8	5 NO 3 NC	CR120BL053**	\$264.00
8	6 NO 2 NC	CR120BL062**	\$264.00
8	7 NO 1 NC	CR120BL071**	\$264.00
8	8 NO 0 NC	CR120BL080**	\$251.00

**Insert coil number from appropriate suffix table to complete product number.

CR120BD DC Operated Relays

No. of Poles	Contact Configuration	Product Number	List Price GO-10G4
2	0 NO 2 NC	CR120BD002††	\$120.00
2	1 NO 1 NC	CR120BD011††	\$120.00
2	2 NO 0 NC	CR120BD020††	\$108.00
3	0 NO 3 NC	CR120BD003††	\$132.00
3	1 NO 2 NC	CR120BD012††	\$132.00
3	2 NO 1 NC	CR120BD021††	\$132.00
3	3 NO 0 NC	CR120BD030††	\$120.00
5	0 NO 5 NC	CR120BD005††	\$156.00
5	1 NO 4 NC	CR120BD014††	\$156.00
5	2 NO 3 NC	CR120BD023††	\$156.00
5	3 NO 2 NC	CR120BD032††	\$156.00
5	4 NO 1 NC	CR120BD041††	\$156.00
5	5 NO 0 NC	CR120BD050††	\$144.00
7	0 NO 7 NC	CR120BD007††	\$180.00
7	1 NO 6 NC	CR120BD016††	\$180.00
7	2 NO 5 NC	CR120BD025††	\$180.00
7	3 NO 4 NC	CR120BD034††	\$180.00
7	4 NO 3 NC	CR120BD043††	\$180.00
7	5 NO 2 NC	CR120BD052††	\$180.00
7	6 NO 1 NC	CR120BD061††	\$180.00
7	7 NO 0 NC	CR120BD070††	\$168.00
9	2 NO 7 NC	CR120BD027††	\$204.00
9	3 NO 6 NC	CR120BD036††	\$204.00
9	5 NO 4 NC	CR120BD054††	\$204.00
9	7 NO 2 NC	CR120BD072††	\$204.00
9	9 NO 0 NC	CR120BD090††	\$192.00
11	8 NO 3 NC	CR120BD083††	\$228.00
11	6 NO 5 NC	CR120BD065††	\$228.00
11	4 NO 7 NC	CR120BD047††	\$228.00
11	11 NO 0 NC	CR120BD110††	\$216.00

†† Insert coil number from appropriate suffix table to complete product number. An additional pole is automatically included in the coil circuit of DC relays.

**AC Coil Suffix Table

Frequency	120 V/110 V	230 V	460 V/380
60 Hz/50 Hz	02	03 ¹	04 ¹

¹60 Hz only.

Insert where ** appears in product number, AC relays only.

††DC Coil Suffix Table

24 V	48 V	125V
48	49	41

Insert where †† appears in product number, DC relays only.

Technical Data

Coil Data

	Inrush VA	Sealed VA	Sealed Watts
AC Relay Coil	120	15	7
AC Unlatch Coil	31	15	9.2

Contact Ratings-All Relays

Maximum Voltage	AC Continuous Rating Ampere	Max. AC Voltampere Rating Make	Max. AC Rating Amps Break
600 VAC	10	7200	720 60 6



Logic Control Industrial/Machine Tool Relays

Section 10

CR120BP

AC Operated Weld Check Relays

600 V

10 Amperes Continuous

60 Hz

Description

The CR120BP Series A industrial relay is designed so that if a normally open contact should weld closed, the normally closed contacts will not reclose when the relay coil is de-energized. When correctly designed into the circuit, this provides a self-checking function. These relays are commonly used for punch press control circuits or on other applications where each relay operation should be checked for proper functioning.

Product Number Selection Instructions

1. Specify by complete product number, including coil suffix in place of **.
Example: For a six-pole relay with four-NO and two-NC poles, a coil operating on 120 Volts, 60 Hertz, order CR120B04202 (complete relay), at **\$132.00, GO-10G4.**

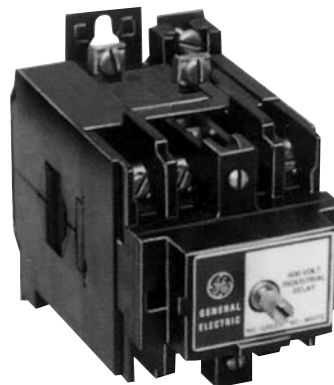

Typical CR120BP Relay

Reference Publications

CR120B Instructions

GEH-4139



Logic Control Industrial/Machine Tool Relays

CR120BP

AC Operated Weld Check Relays

CR120BP

No. of Poles	Contact Configuration	Product Number	List Price GO-10G4
2	2 NO 0 NC	CR120BP020**	\$72.00
2	1 NO 1 NC	CR120BP011**	\$84.00
2	0 NO 2 NC	CR120BP002**	\$84.00
3	3 NO 0 NC	CR120BP030**	\$84.00
3	2 NO 1 NC	CR120BP021**	\$96.00
3	1 NO 2 NC	CR120BP012**	\$96.00
3	0 NO 3 NC	CR120BP003**	\$96.00
4	4 NO 0 NC	CR120BP040**	\$96.00
4	3 NO 1 NC	CR120BP031**	\$108.00
4	2 NO 2 NC	CR120BP022**	\$108.00
4	1 NO 3 NC	CR120BP013**	\$108.00
4	0 NO 4 NC	CR120BP004**	\$108.00
6	6 NO 0 NC	CR120BP060**	\$120.00
6	5 NO 1 NC	CR120BP051**	\$132.00
6	4 NO 2 NC	CR120BP042**	\$132.00
6	3 NO 3 NC	CR120BP033**	\$132.00
6	2 NO 4 NC	CR120BP024**	\$132.00
6	1 NO 5 NC	CR120BP015**	\$132.00
6	0 NO 6 NC	CR120BP006**	\$132.00
8	8 NO 0 NC	CR120BP080**	\$144.00
8	7 NO 1 NC	CR120BP071**	\$156.00
8	6 NO 2 NC	CR120BP062**	\$156.00
8	5 NO 3 NC	CR120BP053**	\$156.00
8	4 NO 4 NC	CR120BP044**	\$156.00
8	3 NO 5 NC	CR120BP035**	\$156.00
8	2 NO 6 NC	CR120BP026**	\$156.00
8	1 NO 7 NC	CR120BP017**	\$156.00
8	0 NO 8 NC	CR120BP008**	\$156.00
12	12 NO 0 NC	CR120BP120**	\$192.00
12	10 NO 2 NC	CR120BP102**	\$204.00
12	8 NO 4 NC	CR120BP084**	\$204.00
12	6 NO 6 NC	CR120BP066**	\$204.00
12	4 NO 8 NC	CR120BP048**	\$204.00

**Insert coil number from Coil Suffix Table to complete product number.

**Coil Suffix Table

Frequency	115 V/120 V	230 V	460 V
60 Hz	02	03	04

Insert where ** appears in product number.

Technical Data

Contact Ratings-All Relays

Maximum Voltage	AC Continuous Rating Ampere	AC Voltampere Rating		Max. Amp Rating	
		Make	Break	Make	Break
600 VAC	10	7200	720	60	6



Logic Control Industrial/Machine Tool Relays

Section 10

CR120B

Standard Components

CR120BL Latch Attachment

The latch attachment mounts on any standard CR120B relay (maximum of eight poles), in the same manner as a deck adder.

Relay Prefix	Product Number	List Price GO-10G4
CR120B	CR120BL000**	\$84.00



Latch Attachment

Replacement Coils for Magnetic Relays - 120B Series

Product Type	Relay/Contactor Prefix	For Use With	Coil Voltage	Frequency	Product Number	List Price GO-11G
AC Replacement Coil	CR120B	Series A Relays	115	60 Hz	55-513696G002	\$46.00
AC Replacement Coil	CR120B	Series A Relays	120	60 Hz	55-513696G022 ¹	\$46.00
AC Replacement Coil	CR120B	Series A Relays	230	60 Hz	55-513696G003	\$46.00
AC Replacement Coil	CR120B	Series A Relays	460	60 Hz	55-513696G004	\$46.00
AC Replacement Coil	CR120B	Series A Relays	380	50 Hz	55-513696G004	\$46.00



Replacement Coil for CR120B
Series A Relays

Contact Cartridge

The same contact cartridge is used in all three decks of the relay. It is easily convertible from NO to NC and vice versa.

Relay Prefix	Product Number	List Price GO-10G4
CR120B	CR120BX1 ² (NO Contact)	\$12.00
CR120B	CR120BX1C ² (NC Contact)	\$12.00



Contact Cartridge

Base Relay Assembly

The base assembly consists of a standard four-pole relay without contact cartridges. One through four contact cartridges (CR120BX1) may be added as required.

Relay Prefix	Product Number	List Price GO-10G4
CR120B	CR120B000** (AC form)	\$48.00
CR120B	CR120BD000†† (DC form)	\$84.00

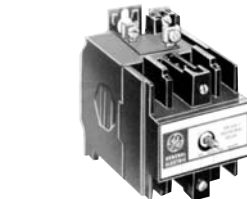

Base Relay Assembly

First Adder Deck Kit

The first adder deck is supplied with one NO contact cartridge. It can accommodate one to four contact cartridges as required. It mounts on the base relay assembly, expanding the relay to a maximum of eight poles.

Relay Prefix	Product Number	List Price GO-10G4
CR120B, BD	CR120BX3 ³	\$12.00
CR120BP	CR120BX21 ³	\$12.00

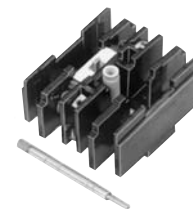

First Adder Deck Kit

Second Adder Deck Kit

The second adder deck is supplied with four NO contact cartridges. The second adder deck mounts on the first adder deck or eight-pole relay and is used where a relay with 9 to 12 poles is desired.

Relay Prefix	Product Number	List Price GO-10G4
CR120B, BD	CR120BX14 ³	\$48.00
CR120BP	CR120BX22 ³	\$48.00

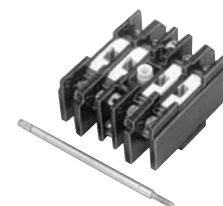

Second Adder Deck Kit

**Insert coil number from AC Coil Suffix Table on page 10-15 to complete product number.

††Insert coil number from DC Coil Suffix table on page 10-15 to complete product number.

¹Coil is dual rated 120V, 60 Hz / 110V, 50 Hz.

²Product number represents one contact cartridge. Packaged in boxes of 20. Order in multiples of 20.
Minimum order quantity is 20.

³Product number represents one adder deck. Packaged in boxes of 10. Order in multiples of 10.
Minimum order quantity is 10.



Product Number Selection Instructions: See page 10-14, 10-16

Logic Control Industrial/Machine Tool Relays

CR120B

Accessories

Surge Suppressor

The surge suppressor is designed to absorb energy surges that appear on the line. It mounts directly on the coil terminals. For use on relay coils of 110-120 Volts, AC.

	Product Number	List Price GO-10G4
	CR120BX2	\$21.00



Surge Suppressor

Indicating Light

An indicating light is provided with mounting bracket and leads. It mounts on any of the standard relays and can be used to monitor the contacts or magnet coil operation.

Rating	Product Number	List Price GO-10G4
110-120 VAC	CR120BX5	\$9.00
220-240 VAC	CR120BX6	\$9.00
440-480 VAC	CR120BX7	\$9.00



Indicating Light

Low-Energy, Gold-Plated Contact Cartridges

This cartridge is similar to the basic relay cartridge except it has gold plating on the contact tips, making it ideal for use in low-energy signal electronics applications.

Description	Product Number	List Price GO-10G4
Separate cartridge	CR120BX1B ¹	\$27.00

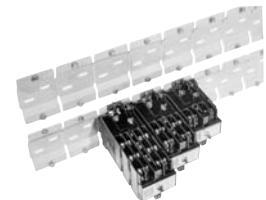

Mounting Track

Mounting Track

The mounting track gives pre-spaced relay mounting, allowing easy installation of relays side by side with optimum spacing, and is available in either nonbreakaway or breakaway form. The breakaway design allows the desired length to be broken off and attached to the panel. All types of mounting track are 40 inches in length and mount 16 relays.

Description	Product Number	List Price GO-10G4
Nonbreakaway Type	CR120BX18	\$16.50
Universal Type	CR120BX23	\$16.50
Breakaway Type	CR120BX4	\$16.50



Manual Operator Tool

Manual Operator Tool

This tool is used on the manual operator to hold relays in the energized position so that panel circuits can be checked.

	Product Number	List Price GO-10G4
	CR120BX16 ¹	\$2.40

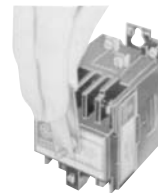

Overlapping Contact Cartridges

Overlapping Contact Cartridges

Overlapping contacts are used in circuits where it is necessary to close one contact before opening another. These are similar to standard contacts except the normally open contact closes early and the normally closed contact opens late. Requires at least two overlapping cartridges per relay.

Description	Product Number	List Price GO-10G4
Separate cartridge	CR120BX1A ¹	\$24.00

NEMA Type 1 Enclosure (without Relays)

Enclosure Will House	Product Number	List Price GO-10G4
8-pole relay	CR120BX15	\$18.00
4-pole solid-state time-delay relay		
4-pole latched relay		

¹Product number represents one piece. Packaged in boxes of ten. Order in multiples of ten. Minimum order quantity is ten.



Logic Control Industrial/Machine Tool Relays

Section 10

CR120B

Outlines and Dimensions ($\frac{\text{in}}{\text{mm}}$) For Estimating Only

CR120B AC and DC Relays

No. of Poles	A Dimension in. (mm)	Approx. Shipping Weight (lbs)
4	4.50 (114.3)	1 1/2
8	5.69 (144.5)	1 7/8
12	6.88 (174.8)	2 1/8

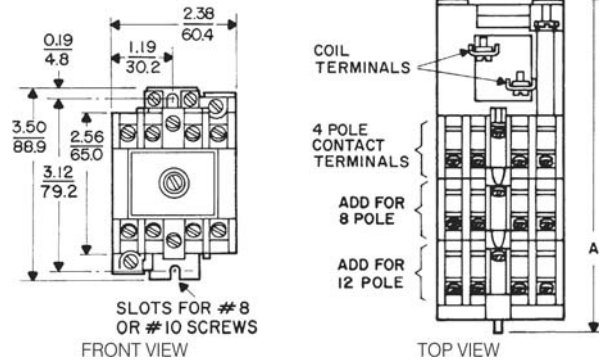

CR120B AC and DC Operated Relays

CR120BL Latch Relays

No. of Poles	A Dimension in. (mm)	Approx. Shipping Weight (lbs)
4	6.62 (168.1)	2 1/4
8	7.81 (198.4)	2 5/8

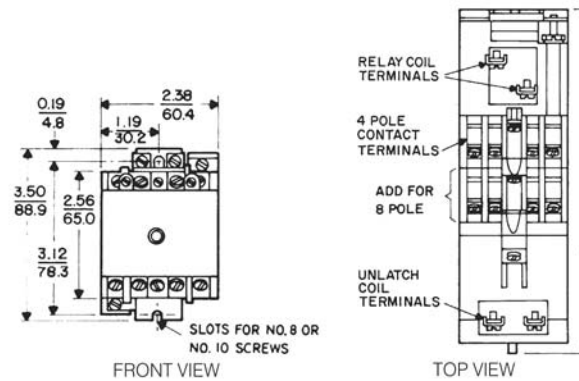

CR120BL AC Operated Latched Relay

CR120BP Weld Check Relays

No. of Poles	A Dimension in. (mm)	Approx. Shipping Weight (lbs)
2	5.03 (127.8)	1 1/2
3	5.03 (127.8)	1 1/2
4	5.03 (127.8)	1 1/2
6	6.19 (157.2)	2
8	6.19 (157.2)	2
12	7.34 (186.4)	2 1/4

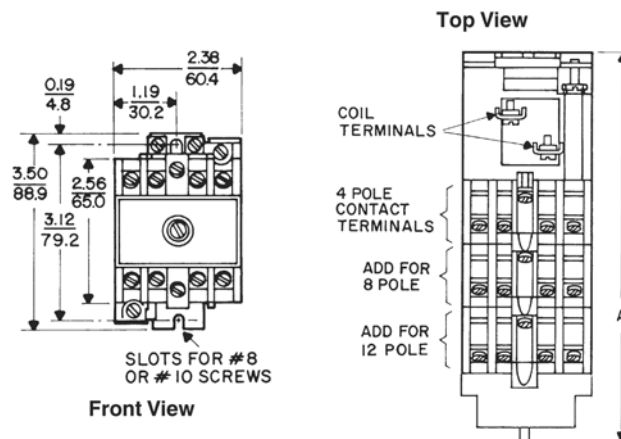

CR120BP Weld Check Relays



Product Number Selection Instructions: See page 10-14, 10-16

Logic Control Industrial/Machine Tool Relays CR120B

Outlines and Dimensions ($\frac{in}{mm}$) For Estimating Only

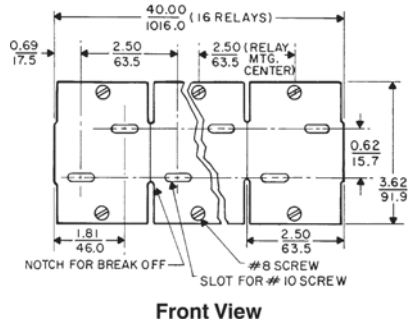

CR120BX4 Mounting Track—Breakaway Type

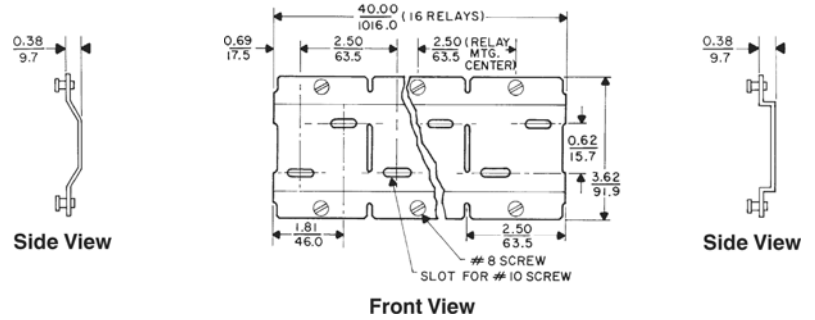

CR120BX18 Mounting Track—Nonbreakaway Type

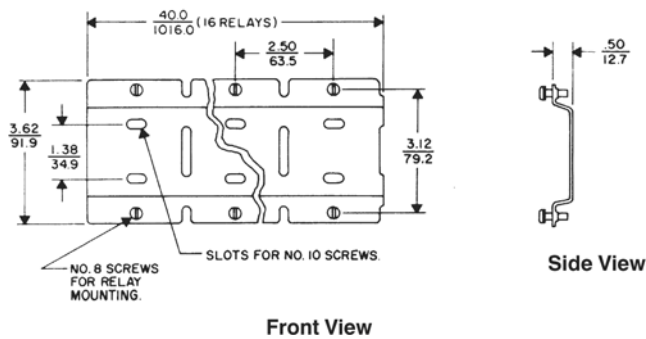

CR120BX23 Mounting Track—Universal Type



Logic Control IEC Electronic Timers Product Overview

Section 10

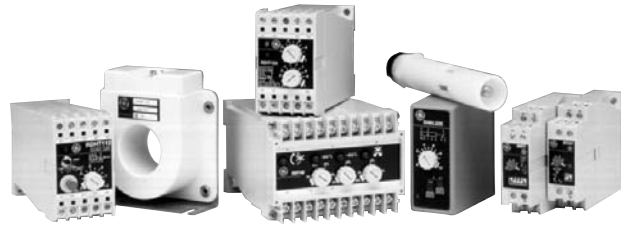

Multivoltage Electronic Timers

Voltage		Multivoltage								
Types		NMTCV	NMTCIV	NMETV	NMTDV	NMRDV	NMICV	NMIFV	NMIVV	NMFEV
	Selection/Pricing Page	10-23	10-23	10-23	10-24	10-23	10-23	10-24	10-24	10-24
	Technical Data Page	10-26	10-27	10-28	10-29	10-29	10-27	10-30	10-30	10-31
Functions										
Delayed ON		•								•
ON delay with auxiliary contact										•
ON delay + instantaneous contact			•							
OFF delay					•	•				
OFF delay with auxiliary contact				•						•
ON + OFF delay with auxiliary contact										•
Impulse ON							•			•
Impulse ON with auxiliary contact										•
OFF pulse with auxiliary contact										•
Symmetric intermittence								•		
Asymmetric intermittence									•	
Star-delta starter				•						
Multifunction										•
Features										
Multirange of time		•	•		•		•	•	•	•
Time setting range	from	0.06 s	0.06 s	6 s	0.06 s	0.5 s	0.06 s	0.06 s	0.06 s	0.6 s
	to	100 hrs	100 hrs	60 s	100 hrs	600 s	100 hrs	100 hrs	100 hrs	100 hrs
Relay output (Number of changeover contacts)		1	1 del +	1	1	1	1	1	1	1
		2	1 inst			2	2	2	2	2



Logic Control IEC Electronic Timers Multivoltage Electronic Timers

Section 10

Delayed ON (See page 10-26 for technical data)

Input Voltage	Contact Configuration	Time Range	Product Number ¹	List Price GO-10RT
Direct 24-240V AC/DC	1 selectable NO-NC	0.06 sec. - 100 hrs	NMTCV	\$61.00
Direct 24-240V AC/DC	2 selectable NO-NC	0.06 sec. - 100 hrs	NMTCV2	\$75.00
With transformer	1 selectable NO-NC	0.06 sec. - 100 hrs	NMTCVT**	\$79.00



Delayed ON

Delayed ON with Instantaneous Contact (See page 10-27 for technical data)

Input Voltage	Contact Configuration	Time Range	Product Number	List Price GO-10RT
Direct 24-240V AC/DC	1 timed contact + 1 instant contact	0.06 sec. - 100 hrs	NMTCIV	\$64.00



Delayed ON w/
Instantaneous Contact

Impulse On (See page 10-27 for technical data)

Input Voltage	Contact Configuration	Time Range	Product Number ¹	List Price GO-10RT
Direct 24-240V AC/DC	1 selectable NO-NC	0.06 sec. - 100 hrs	NMICV	\$65.00

Star-Delta Starter (See page 10-28 for technical data)

Input Voltage	Contact Configuration	Time Range	Product Number ¹	List Price GO-10RT
Direct 24-240V AC/DC	2 timed	6 - 60 sec.	NMETV	\$89.00
With transformer	2 timed	6 - 60 sec.	NMETVT**	\$107.00

Delayed OFF (See page 10-29 for technical data)

Input Voltage	Contact Configuration	Time Range	Product Number ¹	List Price GO-10RT
Direct 24-240V AC/DC	1 selectable NO-NC	0.5 - 6 sec.	NMRDV-6	\$81.00
Direct 24-240V AC/DC	1 selectable NO-NC	5 - 60 sec.	NMRDV-60	\$81.00
Direct 24-240V AC/DC	1 selectable NO-NC	50 - 600 sec.	NMRDV-600	\$81.00
Direct 24-240V AC/DC	2 selectable NO-NC	0.5 - 6 sec.	NMRDV2-6	\$89.00
Direct 24-240V AC/DC	2 selectable NO-NC	5 - 60 sec.	NMRDV2-60	\$89.00
Direct 24-240V AC/DC	2 selectable NO-NC	50 - 600 sec.	NMRDV2-600	\$89.00
With transformer (up to 440V)	1 selectable NO-NC	0.5 - 6 sec.	NMRDVT-6**	\$93.00
With transformer (up to 440V)	1 selectable NO-NC	5 - 60 sec.	NMRDVT-60**	\$93.00
With transformer (up to 440V)	1 selectable NO-NC	50 - 600 sec.	NMRDVT-600**	\$93.00



Delayed OFF

¹To complete the product number, replace the symbol ** with the code corresponding to the voltage.

**Coil Voltage

AC (50/60 Hz)	Coil Digits
110-125	AJ
200-240	AM
380-400	AU

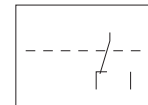

1NO-1NC

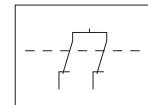

2NO-2NC

Contact Diagrams

Technical Data

Type	See Page
NMTCV	10-26
NMTCIV	10-27
NMICV	10-27
NMETV	10-28
NMRDV	10-29

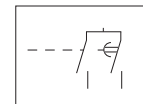

2 Timed

Contact Diagrams



Logic Control

IEC Electronic Timers

Multivoltage Electronic Timers

Section 10

Delayed OFF Through Contact (See page 10-29 for technical data)

Input Voltage	Contact Configuration	Time Range	Product Number ¹	List Price GO-10RT
Direct 24-240V AC/DC	1 selectable NO-NC	0.06 sec. - 100 hrs.	NMTDV	\$56.00



Delayed OFF Through Contact

Symmetric Intermittence (See page 10-30 for technical data)

Input Voltage	Contact Configuration	Time Range	Product Number ¹	List Price GO-10RT
Direct 24-240V AC/DC	1 selectable NO-NC	0.06 sec. - 100 hrs.	NMIFV	\$108.00



Symmetric Intermittence

Asymmetric Intermittence (started by Connection or Pause-Choice) (See page 10-31 for technical data)

Input Voltage	Contact Configuration	Time Range	Product Number ¹	List Price GO-10RT
Direct 24-240V AC/DC	1 selectable NO-NC	0.06 sec. - 100 hrs.	NMIVV	\$108.00



Multifunction

Multifunction and Multirange-Large 45 mm (See page 10-31 for technical data)

The functions of this multifunction and multirange electronic relay are selected by 3 dip-switches located on the front of the relay. It has eight functions:

- Delayed ON timer
- Delayed ON through contact timer
- Delayed OFF through contact timer
- Delayed ON and OFF through contact timer
- Impulse ON timer
- Impulse ON through contact timer
- Impulse OFF through contact timer
- Impulse ON and OFF through contact timer

If the relay loses current during timing, it disconnects and is ready for a new cycle. It has four timing ranges: 0.6-6s, 6-60s, 0.6-6min, 6-60min. Times are set by front potentiometer controlling an ASIC specially designed for this group of relays. This allows for excellent precision and repeatability features.

Type	Input Voltage	Contact Configuration	Time Range	Product Number ¹	List Price GO-10RT
Multifunction	Direct 24-240V AC/DC	1 selectable NO-NC	0.6 sec. - 100 hrs.	NMMFV	\$120.00

¹To complete the product number, replace the symbol ** with the code corresponding to the voltage.

**Coil Voltage

AC (50/60 Hz)	Coil Digits
110-125	AJ
200-240	AM
380-400	AU



Multirange-Large 45 mm

Technical Data

Type	See Page
NMTDV	10-29
NMIFV	10-30
NMIVV	10-30
NMMFV	10-31

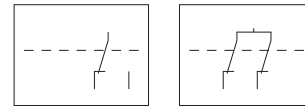

1NO-1NC

2NO-2NC

Contact Diagrams



Logic Control

IEC Electronic Timers

Multivoltage Electronic Timers

Technical Data

****Available Input Voltages**

	Direct supply	Supplied with internal transformer		
	AC (50/60 Hz)/DC	AC (50/60Hz)		
Current				
Voltage	24-240	110-125	200-240	380-400
Product Number Code	None	AJ	AM	AU
NMETV	••			
NMETVT		••	•	•
NMICV	••			
NMIFV	••			
NMIVV	••			
NMMFV	••			
NMRDV	••			
NMRDV2	••			
NMRDVT		••	•	•
NMTCIV	••			
NMTCV	••			
NMTCV2	••			
NMTCVT		••	•	•
NMTDV	••			

- available
- recommended stock



Logic Control

IEC Electronic Timers

Multivoltage Electronic Timers

Technical Data

Section 10

NMTCV Delayed ON Timer

Electronic relay whose output contact connects with a certain adjustable delay from the moment voltage is applied to supply terminals A1-A2. It has four timing ranges: see drawing. Range selection is made by dip-switches located on the front of the relay. Times are set by front potentiometer controlling an Application Specific Integrated Circuit (ASIC) specially designed for this group of relays. This allows for excellent precision and repeatability features.

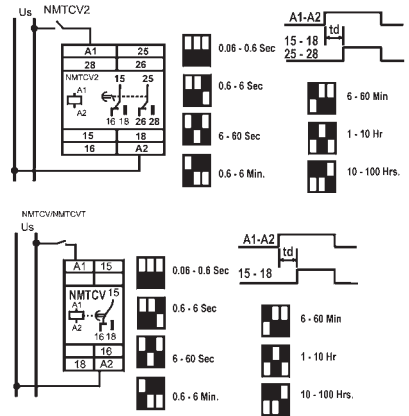

Product Number	NMTCV	NMTCV2	NMTCVT
Number of Selectable NO-NC Contacts	1	2	1
Output Contacts Rated Insulation Voltage: Ui AC	250V	250V	250V
Output Contacts Rated Insulation Voltage: Ui DC	250V	250V	250V
Output Contacts Thermal Current Ith	6A	6A	6A
Utilization Category AC15 Rated Voltage Ue	120/230V	120/230V	120/230V
Utilization Category AC15 Rated Current Ie	2.5/1.3A	2.5/1.3A	2.5/1.3A
Utilization Category DC13 Rated Voltage Ue	120/230V	110/230V	110/230V
Utilization Category DC13 Rated Current Ie	0.2/0.1A	0.2/0.1A	0.2/0.1A
Supply Voltage: AC (with transformer) Un	-	-	110-125V, 200-240V, 380-440V
Supply Voltage: DC/AC (direct)	24-240V	24-240V	-
Line Voltage Frequency	50/60 Hz	50/60 Hz	50/60 Hz
Supply Voltage Tolerance	+10/-20%	+10/-20%	+10/-15%
Consumption (mA)	60 (24V), 15 (240V)	60 (24V), 15 (240V)	-
Consumption (VA)	-	-	3.5
Input Circuit Test Voltage	2 kV	4 kV	4 kV
Switch ON Response Time	0.06 sec.-100 hrs.	0.06 sec.-100 hrs.	0.06 sec.-100 hrs.
Switch OFF Response Time	150 ms	150 ms	150 ms
Reset Time Between 2 Cycles	100 ms	100 ms	100 ms
Repeat Accuracy with 0.85 - 1.1 Un	1%	1%	1%
Weight	0.120, .26 lbs.	0.120, .26 lbs.	0.120, .26 lbs.
Approval & Standards	VDE 0106, VDE 0110, EN 50001, EN 50002, CSA C 22.2 N° 14, UL 94, UL 508, IEC 255.5		

For ambient conditions data see p. 10-32, Table 2. The relays have a green LED that lights when the relay is energized (flashing during the timing) and a red LED that lights when the output contact is made.



Logic Control

IEC Electronic Timers

Multivoltage Electronic Timers

Technical Data

NMTCIV Delayed ON Timer with Instantaneous Contact

Electronic relay with two output contacts. One contact connects instantly when voltage is applied to the supply terminals A1-A2 and the other connects with a certain adjustable delay. It has four timing ranges: see drawing. Range selection is made by dip-switches located on the front of the relay. Times are set by front potentiometer controlling an ASIC specially designed for this group of relays. This allows for excellent precision and repeatability features.

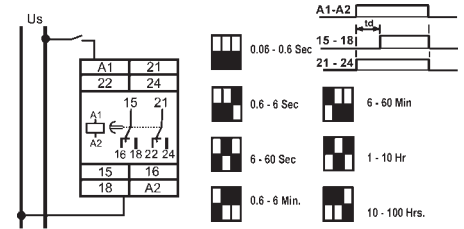

Product Number	NMTCIV
Number of Selectable NO-NC Contacts	2
Output Contacts Rated Insulation Voltage: Ui AC	250V
Output Contacts Rated Insulation Voltage: Ui DC	250V
Output Contacts Thermal Current Ith	6A
Utilization Category AC15 Rated Voltage Ue	125/230V
Utilization Category AC15 Rated Current Ie	2.5/1.3A
Utilization Category DC13 Rated Voltage Ue	110/230V
Utilization Category DC13 Rated Current Ie	0.2/0.1A
Supply Voltage: DC/AC (direct) Un	24-240V
Line Voltage Frequency	50/60 Hz
Supply Voltage Tolerance	+10/-20%
Consumption (mA)	60 (24V), 15 (240V)
Input Circuit Test Voltage	2 kV
Switch ON Response Time	0.06 sec.-100 hrs.
Switch OFF Response Time	150 ms
Reset Time Between 2 Cycles	100 ms
Repeat Accuracy with 0.85 - 1.1 Un	1%
Weight	0.130, .28 lbs.
Approval & Standards	VDE 0106, VDE 0110, EN 50002, EN 50042, CSA C 22.2 N° 14, UL 94, UL 508, IEC 255.5, IEC 947.5.1, UNE20-119

For ambient conditions data see p. 10-32, Table 1. The relays have a green LED that lights when the relay is energized (flashing during the timing) and a red LED that lights when the output contact is made.

NMICV Impulse ON Timer

Electronic relay whose output contact connects when voltage is applied to supply terminals A1-A2. It goes back to stand-by after a preset time. It has four timing ranges: see drawing. Range selection is made by dip-switches located on the front of the relay. Times are set by front potentiometer controlling an Application Specific Integrated Circuit (ASIC) specially designed for this group of relays. This allows for excellent precision and repeatability features.

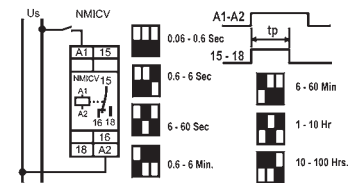

Product Number	NMICV
Number of Selectable NO-NC Contacts	1
Output Contacts Rated Insulation Voltage: Ui AC	250V
Output Contacts Rated Insulation Voltage: Ui DC	250V
Output Contacts Thermal Current Ith	6A
Utilization Category AC15 Rated Voltage Ue	125/230V
Utilization Category AC15 Rated Current Ie	2.5/1.3A
Utilization Category DC13 Rated Voltage Ue	110/230V
Utilization Category DC13 Rated Current Ie	0.2/0.1A
Supply Voltage: AC (with transformer) Un	-
Supply Voltage: DC/AC (direct)	24-240V
Line Voltage Frequency	50/60 Hz
Supply Voltage Tolerance	+10/-20%
Consumption (mA)	60 (24V) 15 (240V)
Consumption (VA)	-
Input Circuit Test Voltage	2 kV
Switch ON Response Time	100 ms
Switch OFF Response Time	0.06 sec.-100 hrs.
Reset Time Between 2 Cycles	100 ms
Repeat Accuracy with 0.85 - 1.1 Un	1%
Weight	0.120, .26 lbs.
Approval & Standards	VDE 0106, VDE 0110, EN 50002, EN 50042, CSA C 22.2 N° 14, UL 508, IEC 255.5, IEC 947.5.1, UNE20-119

For ambient conditions data see p. 10-32, Table 1. The relays have a green LED that lights when the relay is energized (flashing during the timing) and a red LED that lights when the output contact is made.



Logic Control

IEC Electronic Timers

Multivoltage Electronic Timers

Technical Data

NMETV Star-Delta Starter Timer

Electronic relay timed in steps whose purpose is to control star-delta starting. When supply voltage is applied to the A1-A2 terminals, the star contact (17-18) closes for an adjustable time between 6 and 60 sec. (selectable). When this time is up, it opens, there is a pause and then the delta contact connects (17-18). The standard pause time is about 100ms. Times are set by front potentiometer controlling an ASIC specially designed for this group of relays. This allows for excellent precision and repeatability features.

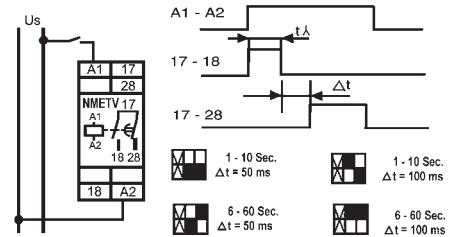

Product Number	NMETV	NMETVT
Number of Selectable NO-NC Contacts	2	2
Output Contacts Rated Insulation Voltage: Ui AC	250V	250V
Output Contacts Rated Insulation Voltage: Ui DC	250V	250V
Output Contacts Thermal Current Ith	6A	6A
Utilization Category AC15 Rated Voltage Ue	120/230V	120/230V
Utilization Category AC15 Rated Current Ie	2.5/1.3A	2.5/1.3A
Utilization Category DC13 Rated Voltage Ue	110/230V	110/230V
Utilization Category DC13 Rated Current Ie	0.2/0.1A	0.2/0.1A
Supply Voltage: AC (with transformer) Un	-	110-125V, 200-240V, 380-440V
Supply Voltage: DC/AC (direct) Un	24-240V	-
Line Voltage Frequency	50/60 Hz	50/60 Hz
Supply Voltage Tolerance	+10/-20%	+10/-15%
Consumption (mA)	50 mA (24V), 12 mA (240)	-
Consumption (VA)	-	3.5 VA
Input Circuit Test Voltage	4 kV	4 kV
Switch ON Response Time	100 ms	100 ms
Reset Time Between 2 Cycles	100 ms	100 ms
Repeat Accuracy with 0.85 - 1.1 Un	2%	2%
Weight	0.130, .28 lbs.	0.130, .28 lbs.
Approval & Standards	VDE 0106, VDE 0110, EN 50001, EN 50002, CSA C 22.2 N° 14, UL 508, IEC 255.5	

For ambient conditions data see p. 10-32, Table 2. The relays have a green LED that lights when the relay is energized (flashing during the timing) and a red LED that lights when the output contact is made.



Logic Control

IEC Electronic Timers

Multivoltage Electronic Timers

Technical Data

NMRDV Delayed OFF Timer

Electronic relay whose output contact instantly connects when supply voltage is applied to terminals A1-A2. It disconnects with an adjustable delay from the moment the relay loses supply voltage. There are several types depending on the range of timers. There are several types depending on the range of timers.

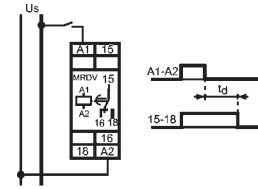

Product Number	NMRDV	NMRDV2	NMRDVT
Number of Selectable NO-NC Contacts	1	2	1
Output Contacts Rated Insulation Voltage: Ui AC	250V	250V	250V
Output Contacts Rated Insulation Voltage: Ui DC	250V	250V	250V
Output Contacts Thermal Current Ith	6A	6A	6A
Utilization Category AC15 Rated Voltage Ue	125/230V	125/230V	125/230V
Utilization Category AC15 Rated Current Ie	2.5/1.3A	2.5/1.3A	2.5/1.3A
Utilization Category DC13 Rated Voltage Ue	110/230V	110/230V	110/230V
Utilization Category DC13 Rated Current Ie	0.2/0.1A	0.2/0.1A	0.2/0.1A
Supply Voltage: AC (with transformer) Un	-	-	110-127V, 200-240V, 380-440V
Supply Voltage: DC/AC (direct) Un	24-240V	24-240V	-
Line Voltage Frequency	50/60 Hz	50/60 Hz	50/60 Hz
Supply Voltage Tolerance	+10/-20	+10/-20	+10/-15
Consumption (mA)	60 (at 24V), 15 (at 240V)	1.5 (at 24V), 5 (at 240V)	-
Consumption (VA)	-	-	3.5
Input Circuit Test Voltage	4 kV	4 kV	4 kV
Switch ON Response Time	250 ms ¹	250 ms ¹	250 ms ¹
Switch OFF Response Time	0.5 - 600s	0.5 - 600s	0.5 - 600s
Reset Time Between 2 Cycles	250 ms	250 ms	250 ms
Repeat Accuracy with 0.85 - 1.1 Un	5%	5%	5%
Weight	0.130, .28 lbs.	0.130, .28 lbs.	0.130, .28 lbs.
Approval & Standards	VDE 0106, VDE 0110, EN 50002, EN 50042, CSA C 22.2 N° 14, UL 508, IEC 255.5, IEC 947.5.1, UNE 20-119		

For ambient conditions data see p. 10-32, Table 1. The relays have a green LED that lights when the relay is energized (flashing during the timing) and a red LED that lights when the output contact is made.

¹For 24VDC = 300 ms.

NMTDV Delayed OFF Through Contact Timer

Electronic relay whose output contact connects instantly when connecting the Y1-Y2 terminals with a voltage-free control. It disconnects with an adjustable delay when the terminals are disconnected. The relay must be supplied with nominal voltage between A1-A2. Loss of supply voltage causes immediate disconnection. It has timing ranges: see drawing. Range selection is made by dip-switches located on the front of the relay. Times are set by front potentiometer controlling an ASIC specially designed for this group of relays. This allows for excellent precision and repeatability features.

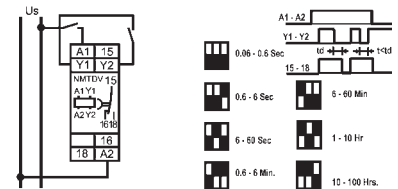

Product Number	NMTDV
Number of Selectable NO-NC Contacts	1
Output Contacts Rated Insulation Voltage: Ui AC	250V
Output Contacts Rated Insulation Voltage: Ui DC	250V
Output Contacts Thermal Current Ith	6A
Utilization Category AC15 Rated Voltage Ue	125/230V
Utilization Category AC15 Rated Current Ie	2.5/1.3A
Utilization Category DC13 Rated Voltage Ue	110/230V
Utilization Category DC13 Rated Current Ie	0.2/0.1A
Supply Voltage: AC (with transformer) Un	-
Supply Voltage: DC/AC (direct) Un	24-240V
Line Voltage Frequency	50/60 Hz
Supply Voltage Tolerance	+10/-20
Consumption (mA)	60 (at 24V), 1.5 (at 240V)
Consumption (VA)	-
Input Circuit Test Voltage	4 kV
Switch ON Response Time	100 ms
Switch OFF Response Time	0.06 sec. - 100 hrs.
Reset Time Between 2 Cycles	100 ms
Repeat Accuracy with 0.85 - 1.1 Un	2%
Voltage at Open Y1 - Y2 Control Terminals	1V DC
Initial Current Through Control Contact	15 mA
Permanent Current Through Control Contact	1 mA
Weight	0.120, .26 lbs.
Approval & Standards	VDE 0106, VDE 0110, EN 50001, EN 50002, CSA C 22.2 N° 14, UL 508, IEC 255.5

For ambient conditions data see p. 10-32, Table 2. The relays have a green LED that lights when the relay is energized (flashing during the timing) and a red LED that lights when the output contact is made.



Logic Control

IEC Electronic Timers

Multivoltage Electronic Timers

Technical Data

NMIFV Symmetric Intermittence Timer

Electronic relay whose output contact connects and disconnects intermittently with a symmetric cycle (connection and pause times are the same). It has six ranges: see drawing. Range selection is made by dip-switches located on the front of the relay. Times are set by front potentiometer controlling an ASIC specially designed for this group of relays. This allows for excellent precision and repeatability features.

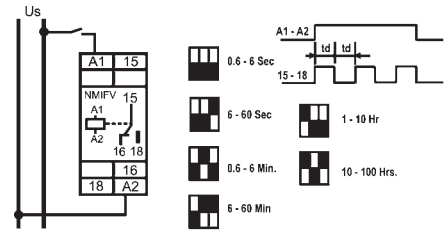

Product Number	NMIFV
Number of Selectable NO-NC Contacts	1
Output Contacts Rated Insulation Voltage: Ui AC	250V
Output Contacts Rated Insulation Voltage: Ui DC	250V
Output Contacts Thermal Current Ith	6A
Utilization Category AC15 Rated Voltage Ue	125/230V
Utilization Category AC15 Rated Current Ie	2.5/1.3A
Utilization Category DC13 Rated Voltage Ue	110/230V
Utilization Category DC13 Rated Current Ie	0.2/0.1A
Supply Voltage: AC (with transformer) Un	-
Supply Voltage: DC/AC (direct) Un	24-240V
Line Voltage Frequency	50/60 Hz
Supply Voltage Tolerance	+10/-20
Consumption (mA)	50 (at 24V), 15 (at 240V)
Consumption (VA)	-
Input Circuit Test Voltage	4 kV
Intermittent Switch Times	0.6 sec. - 100 hrs.
Reset Time Between 2 Cycles	100 ms
Repeat Accuracy with 0.85 - 1.1 Un	2%
Weight	0.120, .26 lbs.
Approval & Standards	VDE 0106, VDE 0110, EN 50002, EN 50042, CSA C 22.2 N° 14, UL 508, IEC 255.5, IEC 947.5.1, UNE 20-119

For ambient conditions data see p. 10-32, Table 1. The relays have a green LED that lights when the relay is energized (flashing during the timing) and a red LED that lights when the output contact is made.

NMIVV Asymmetric Intermittence Timer (started by Connection or Pause-Choice)

Electronic relay whose contact connects and disconnects intermittently. Connection and pause times may be set separately. The intermittency cycle begins with a connection or pause selected by dip-switch and starts the instant connection is made from supply voltage to the A1-A2 terminals. A new step is begun if voltage supply is interrupted during operation. It has four timing ranges: 0.6 sec. - 100 hrs. Range selection is made by dip-switches located on the front of the relay. Times are set by front potentiometer controlling an ASIC specially designed for this group of relays. This allows for excellent precision and repeatability features. This allows for excellent precision and repeatability features.

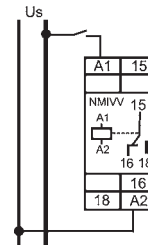

Product Number	NMIVV	NMIVL
Number of Selectable NO-NC Contacts	1	1
Output Contacts Rated Insulation Voltage: Ui AC	250V	250V
Output Contacts Rated Insulation Voltage: Ui DC	50V	50V
Output Contacts Thermal Current Ith	6A	6A
Utilization Category AC15 Rated Voltage Ue	125/230V	120/230V
Utilization Category AC15 Rated Current Ie	2.5/1.3A	2.5/1.3A
Utilization Category DC13 Rated Voltage Ue	110/230V	110/230V
Utilization Category DC13 Rated Current Ie	0.2/0.1A	0.2/0.1A
Supply Voltage: AC (with transformer) Un	-	-
Supply Voltage: DC/AC (direct) Un	24-240V	24-240V
Line Voltage Frequency	50/60 Hz	50/60 Hz
Supply Voltage Tolerance	+10/-20	+10/-20
Consumption (mA)	60 (at 24V), 15 (at 240V)	60 (at 24V), 15 (at 240V)
Consumption (VA)	-	-
Input Circuit Test Voltage	2 kV	2 kV
Switch ON Response Time	150 ms	150 ms
Intermittent Switch ON Times ¹	0.6 sec. - 100 hrs.	0.6 sec. - 100 hrs.
Intermittent Switch OFF Times ¹	0.6 sec. - 100 hrs.	0.6 sec. - 100 hrs.
Reset Time Between 2 Cycles	150 ms	150 ms
Repeat Accuracy with 0.85 - 1.1 Un	1%	1%
Weight	0.120, .26 lbs.	0.120, .26 lbs.
Approval & Standards	VDE 0106, VDE 0110, EN 50002, EN 50005, EN 50042, CSA C 22.2 N° 14, UL 508, IEC 255.5, IEC 947.5.1, UNE 20-119	

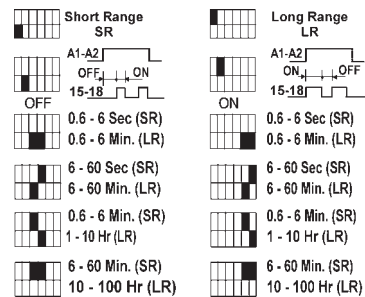

Note: For ambient conditions data see p. 10-32, Table 1. The relays have a green LED that lights when the relay is energized (flashing during the timing) and a red LED that lights when the output contact is made.

¹Connection and pause times may be set within different ranges.



Logic Control

IEC Electronic Timers

Multivoltage Electronic Timers

Technical Data

NMMFV Multifunction Timer

The functions of this multifunction and multirange electronic relay are selected by 3 dip-switches located on the front of the relay. It has eight functions:

- Delayed ON timer
- Delayed ON through contact timer
- Delayed OFF through contact timer
- Delayed ON and OFF through contact timer
- Impulse ON timer
- Impulse ON through contact timer
- Impulse OFF through contact timer
- Impulse ON and OFF through contact timer

If the relay loses current during timing, it disconnects and is ready for a new cycle. It has four timing ranges: see drawing. Times are set by front potentiometer controlling an ASIC specially designed for this group of relays. This allows for excellent precision and repeatability features.

Product Number	NMMFV
Number of Selectable NO-NC Contacts	1
Output Contacts Rated Insulation Voltage: Ui AC	250V
Output Contacts Rated Insulation Voltage: Ui DC	250V
Output Contacts Thermal Current Ith	6A
Utilization Category AC15 Rated Voltage Ue	110/230V
Utilization Category AC15 Rated Current Ie	2.5/1.3A
Utilization Category DC13 Rated Voltage Ue	110/230V
Utilization Category DC13 Rated Current Ie	0.2/0.1A
Supply Voltage: AC (with transformer) Un	-
Supply Voltage: DC/AC (direct) Un	24-240V
Line Voltage Frequency	50-60 Hz
Supply Voltage Tolerance	+10/-20
Consumption (mA)	60 (at 24V), 15 (at 240V)
Consumption (VA)	-
Input Circuit Test Voltage	2 kV
Switch ON Response Times	0.06 sec. - 100 hrs.
Switch OFF Response Times	0.06 sec. - 100 hrs.
Reset Time Between 2 Cycles	150 ms
Repeat Accuracy with 0.85 - 1.1 Un	2%
Voltage at Open Y1 - Y2 Control Terminals	5 V DC
Initial Current Through Control Contact	15 mA
Permanent Current Through Control Contact	1 mA
Weight	0.125, .27 lbs.
Approval & Standards	VDE 0106, VDE 0110, EN 50002, EN 50042, CSA C 22.2 N° 14, UL 508, IEC 255.5, IEC 947.5.1, UNE 20-119

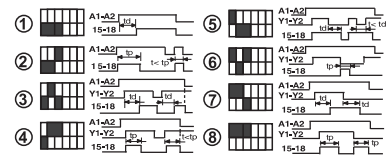
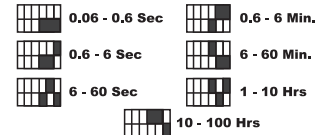
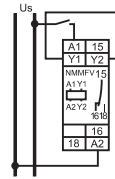

Note: For ambient conditions data see p. 10-32, Table 1. The relays have a green LED that lights when the relay is energized (flashing during the timing) and a red LED that lights when the output contact is made.



Logic Control
IEC Electronic Timers
Outlines and Dimensions [mm (in.)] For Estimating Only

Section 10

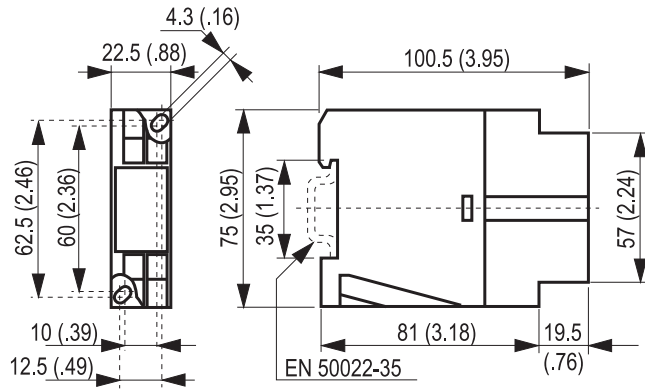

Multivoltage Electronic Timers (except 45 mm form)

Ambient Conditions Data

Ambient Conditions Table 1

Storage Temperature	-10°C to +85°C, 14°F to 185°F
Operating Temperature	-0°C to +50°C, 32°F to 122°F
Relative Humidity	95% (without condensation)
Maximum Operating Altitude	2,000 m, 6,652 ft.
Degree of Protection	IP40 (terminals IP20)
Operating Positions	Any position

Ambient Conditions Table 2

Storage Temperature	-10°C to +85°C, 14°F to 185°F
Operating Temperature	-5°C to +50°C, 23°F to 122°F
Relative Humidity	95% (without condensation)
Maximum Operating Altitude	2,000 m, 6,652 ft.
Degree of Protection	IP40 (terminals IP20)
Operating Positions	Any position





Protective Relays

Voltage		Single voltage						
Types		DINIL	RPDF	RSFF	RMM	RS01N	RSR	RCF
		Selection/Pricing Page	10-34	10-35	10-35	10-35	10-35	10-35
	Technical Data Page	10-37	10-40	10-41	10-41	10-42	10-42	10-43
Functions								
	Liquid level detection	•						
	Differential ground fault							
	Integral protection for three-phase lines							
	Unbalance and phase failure protection		•					
	Unbalance, phase failure, and min. voltage protection							
	Phase sequence and phase failure protection			•				
	Max. and min. voltage protection (single phase)				•			
	Voltage detection							
	Current detection							
	Current detection with delay (0.5-15 s)							
	Thermistor					•		
	Thermistor (adjustable)						•	
	Frequency control							•



Logic Control IEC Protective Relays Liquid Level Detector Relays

Page Updated 12 / 2011

Section 10

Liquid Level Detector Relays (See page 10-37 for technical data)

Input Voltage	Contact Configuration	Number of Circuits	Mounting type	Product Number ¹	List Price GO-10RT
With transformer	1 selectable NO-NC contact	2	DIN-Rail	DINIL 02**	\$155.00
With transformer	1 selectable NO-NC contact	1	DIN-Rail	DINIL 03**	\$190.00
With transformer	1 selectable NO-NC contact	2	Socket	DINIL 02E**	\$125.00
With transformer	1 selectable NO-NC contact	1	Socket	DINIL 03E**	\$150.00



DINIL 02

Liquid Level Detector Relays—Socket for Panel Fixing

Description	Product Number ¹	List Price GO-10PR
11 pin Socket for DINIL 02E and DINIL 03E for panel fixing. Front terminals	CR420KA3**	\$12.00

¹To complete the product number, replace the symbol ** with the code corresponding to the voltage. See page 10-36.



DINIL 03

Liquid Level Detector Relays—Probes

Description	Cable length	Product Number	List Price GO-10RT
Cable union and probe encapsulated and protected by thermoplastic housing. Stainless steel probe.	5 m., 16.4'	SON-1	\$33.00
	10 m., 32.8'	SON-2	\$45.00
Without cable. Waterproof and protected with a thermoplastic housing.	-	SON-3	\$23.00



SON

Technical Data

Type	See Page
DINIL 02	10-37 to 10-38
DINIL 03	10-39
DINIL 02E	10-37 to 10-38
DINIL 03E	10-39



Logic Control IEC Protective Relays Control and Protection Relays

Protective Relays (See page 10-41 for technical data)

Function	Contact Configuration	Operating Range, U min.	Operating Range, U max.	Unbalance	Line Voltage Frequency	Product Number ¹	List Price GO-10RT
Phase sequence and phase failure (three-phase lines with transformer)	1 selectable NO-NC	-	-	-	50 Hz	RSFF1-50**	\$144.00
	1 selectable NO-NC	-	-	-	60 Hz	RSFF1-60**	\$144.00
Maximum and minimum voltage protection (single phase lines with transformer)	2 selectable NO-NC	5 - 20%	5 - 15%	-	50/60 Hz	RMM 2**	\$125.00

¹To complete the product number, replace the symbol ** with the code corresponding to the voltage. See page 10-36.

Technical Data

Type	See Page
RPDF	10-40
RSFF	10-41
RMM	10-41

Thermistor Relays (standard) (See page 10-42 for technical data)

Contact Configuration	Temperature Range	Thermal Probe Resistance Operating Range		Product Number	List Price GO-10RT
		When Cold	When Hot		
1 selectable NO-NC	Standard	1.5 k ohms	2.5 k ohms	RS01N**	\$150.00

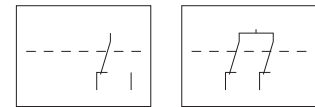

1NO-1NC

2NO-2NC

Contact Diagrams

Thermistor Relays (adjustable) (See page 10-42 for technical data)

Contact Configuration	Temperature Range	Thermal Range with PT100 Probe ³	Product Number ¹	List Price GO-10RT
1 selectable NO-NC	Adjustable	30 - 60°C, 86 - 140°F	RSR1-30**	\$150.00
1 selectable NO-NC	Adjustable	55 - 85°C, 131 - 185°F	RSR1-55**	\$150.00
1 selectable NO-NC	Adjustable	80 - 110°C, 176 - 230°F	RSR1-80**	\$150.00
1 selectable NO-NC	Adjustable	105 - 135°C, 221 - 275°F	RSR1-105**	\$150.00
1 selectable NO-NC	Adjustable	130 - 180°C, 266 - 356°F	RSR1-130**	\$150.00



RSR

Frequency Control Relays (See page 10-43 for technical data)

Contact Configuration	Jumper Terminals	Setting Range	Product Number ¹	List Price GO-10RT
1 selectable NO-NC	Without Y1 - Y2 Y1 - Y3	5 - 15Hz 15 - 45Hz 45 - 135Hz	RCF-1**	\$230.00

¹To complete the product number, replace the symbol ** with the code corresponding to the voltage. See page 10-36.

²Versions in 24V DC only with internal galvanic isolation: RDTA, RDIA, RDITA.

³Thermal probe resistor not included.



RCF-1

Technical Data

Type	See Page
RS01N	10-42
RSR	10-42
RCF	10-43

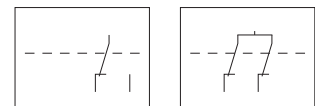

1NO-1NC

2NO-2NC

Contact Diagrams



Logic Control IEC Protective Relays Technical Data

Section 10

Page Updated 04 / 2012

**Available Input Voltages

Current	Direct supply			Supplied with internal transformer																									
	AC/DC	DC		AC (50/60Hz)															AC (50Hz)					AC (60Hz)					
	24-240	24	24	24	48	110-125	110	125	220	220-230	230	240	380-400	380	400	440	500	220	240	380	440	500	220	240	380	440	500		
Product Number Code	None	CD	CD	AD	AG	AJ	AJ	AK	AN	EN	AP	AR	AU	AU	AV	AX	AY	EN	AR	AU	AX	AY	EN	AR	AU	AX	AY		
RCF1				•	•		••	•		•		•	•																
RMM 2		•		•			••	•		•		•		•	•	•	•												
RPDF2-50																		•	•	•	•	•							
RPDF2-60																							•	•	•	•	•		
RS01N		•			•		••	•		•		•	•																
RSFF1-50																		•		•	•								
RSFF1-60																							•		•				
RSR1		•			•		••	•		•		•	•																

- no recommended stock
- recommended stock



DINIL-02 Liquid Level Detector Relays

DINIL-02E Liquid Level Detector Plug-in Relays

DINIL-02 and DINIL-02E are devices to control levels of conductive liquids which perform the following functions:

- Filling control: The contact between 11-14 (DINIL-02) or 1-3 (DINIL-02E) closes when the tank to be checked drops below a minimum, fixed by the position of probe Z23 (DINIL-02) or probe 6 (DINIL-02E), which starts up the pumping system. When the maximum filling level is reached, fixed by the position of probe Z22 (DINIL-02) or probe 7 (DINIL-02E), the contact between 11-14 (DINIL-02) or 1-3 (DINIL-02E) opens and the pumping system stops.
- Draining control: The contact 11-14 (DINIL-02) or 1-3 (DINIL-02E) closes if the level liquid goes above a maximum (fixed by the position of probe Z12 (DINIL-02) or probe 9 (DINIL-02E), which starts up the drain pumping system. When the level drops below a minimum, fixed by the position of probe Z13 (DINIL-02) or probe 8 (DINIL-02E), the contact 11-14 (DINIL-02) or 1-3 (DINIL-02E) opens and stops the pumping system, which prevents the pump from losing its prime.
- Simultaneous filling and draining control: The system starts up whenever the tank requires liquid and the well has sufficient level to supply it. The system stops when the liquid reaches its maximum level in the tank or when the well reaches its minimum level.

Note: In all the above applications, the contact between 11-14 (DINIL-02) or 1-3 (DINIL-02E) is used as a permanent contact for starting and stopping the pump starter, whether it is direct-on-line, star-delta or any other type of starter.

Product Number	DINIL-02	DINIL-02E
Number of Selectable NO-NC Contacts	1	1
Output Contacts Rated Insulation Voltage: Ui AC	400V	400V
Output Contacts Rated Insulation Voltage: Ui DC	250V	250V
Output Contacts Thermal Current Ith	6A	6A
Utilization Category AC15 Rated Voltage Ue	120/240V	120/240V
Utilization Category AC15 Rated Current Ie	2.5/1.3A	2.5/1.3A
Utilization Category DC13 Rated Voltage Ue	110/220V	110/220V
Utilization Category DC13 Rated Current Ie	0.2/0.1A	0.2/0.1A
Supply Voltage: AC (with transformer) Un	380-400V, 240V, 220-230V, 125V, 110V, 48V, 24V	380-400/220-230V (two voltages)
Line Voltage Frequency	50/60 Hz	50/60 Hz
Supply Voltage Tolerance	+10/-15%	+10/-15%
Consumption	3VA	3VA
Input Circuit Test Voltage	4 kV	4 kV
Voltage Between Probes and Common	6-18 V ef.	6-18 V ef.
Max. Consumption of Probes	0.18 mA ef.	0.18 mA ef.
Max. Resistance Between Probes	200 k ohm	200 k ohm
Switch ON Response Time	1 s	1 s
Switch OFF Response Time	1 s	1 s
Repeat Accuracy with 0.85 - 1.1 Un	2%	2%
Weight	0.275, .60 lbs.	0.195, .42 lbs.
Approval & Standards	VDE 0106 EN 50001 EN 50005 EN 50011 DIN 46199 IEC 947.5.1 UNE 20119 UL508	VDE 0106 UL508 IEC 947.5.1 UNE 20119

For ambient conditions data see p. 10-45, Table 2.

Note: The relay has one LED that lights when the output contact is made.



Pump-IN control wiring diagram

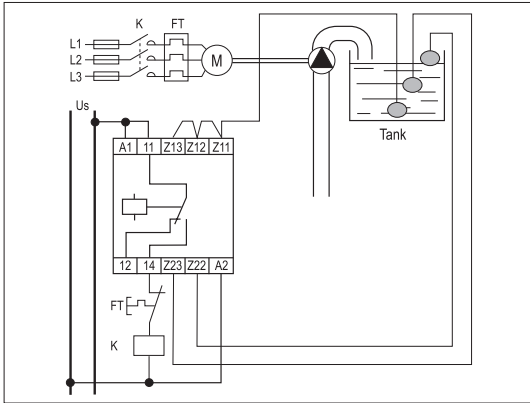

Pump-OUT wiring diagram

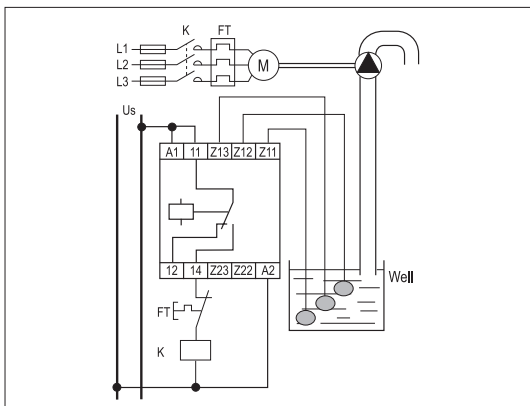

Pump-IN and Pump-OUT control wiring diagram

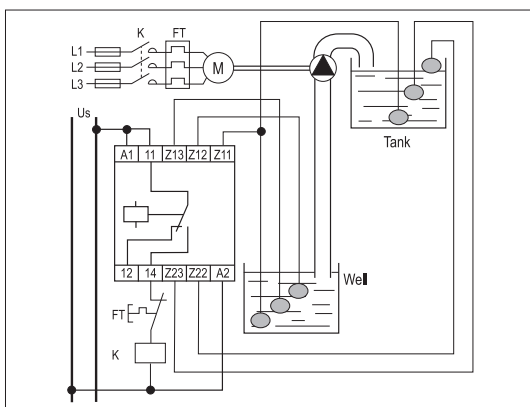

DINIL-02

Pump-IN control wiring diagram

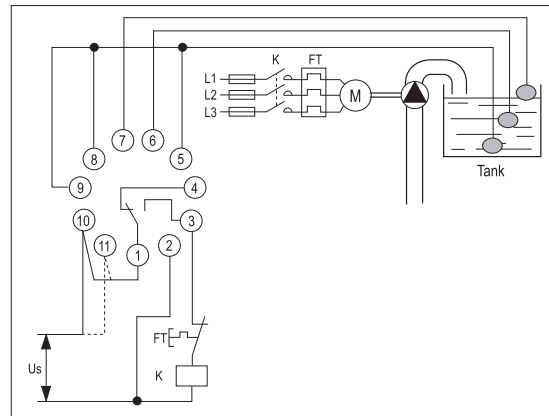

Pump-OUT wiring diagram

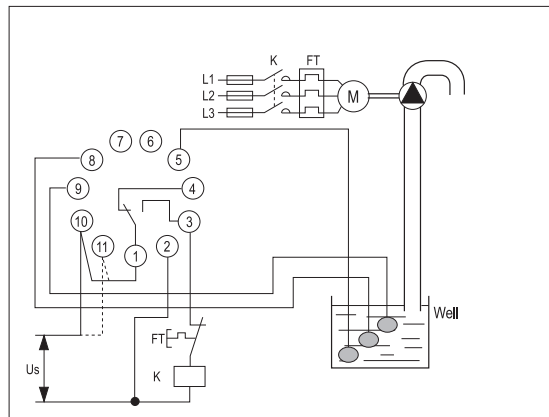

Pump-IN and Pump-OUT control wiring diagram

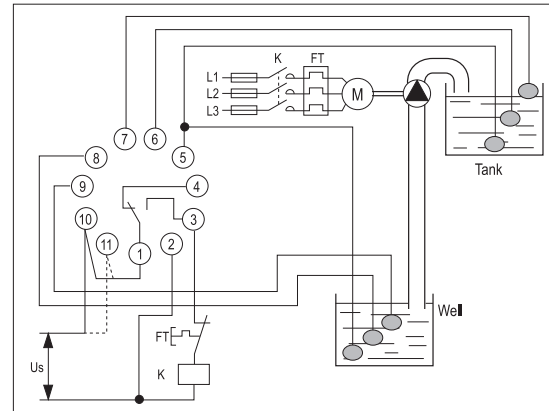

DINIL-02E

Control Voltage

Single Voltage	Dual Voltage
Terminals 2-10	220-230 VAC (Terminals 2-10)
	380-400 VAC (Terminals 2-11)



Logic Control IEC Protective Relays Technical Data

DINIL-03 Liquid Level Detector Relays DINIL-03E Liquid Level Detector Plug-in Relays

DINIL-03 and DINIL-03E are devices to control levels of conductive liquids. They can control the pump-in and pump-out of wells or tanks, but not both simultaneously. They are similar to DINIL-02 / DINIL-02E. The contact 11-14 (DINIL-03) or 1-3 (DINIL-03E), makes if the level is above or equal to the level fixed by prove Z2 (DINIL-03) or probe 9 (DINIL-03E), and breaks if the level falls below the level fixed by probe Z3 (DINIL-03) or probe 8 (DINIL-03E).

—Filling control: The contact 11-12 (DINIL-03) or 1-4 (DINIL-03E) is used for permanent control of the start of the pump.

—Draining control: The contact 11-14 (DINIL-03) or 1-3 (DINIL-03E) is used for permanent control of the pump starting.

Note: The “common” probe must be slightly lower than the “low level” probe and can be connected to the well or tank frame if it is metallic. Sensitivity is adjusted by means of a front potentiometer, and its adjustment position depends on liquid resistivity.

Product Number	DINIL-03	DINIL-03E
Number of Selectable NO-NC Contacts	1	1
Output Contacts Rated Insulation Voltage: Ui AC	400V	400V
Output Contacts Rated Insulation Voltage: Ui DC	250V	250V
Output Contacts Thermal Current Ith	6A	6A
Utilization Category AC15 Rated Voltage Ue	120/240V	120/240V
Utilization Category AC15 Rated Current Ie	2.5/1.3A	2.5/1.3A
Utilization Category DC13 Rated Voltage Ue	110/220V	110/220V
Utilization Category DC13 Rated Current Ie	0.2/0.1A	0.2/0.1A
Supply Voltage: AC (with transformer) Un	380-400V, 240V, 220-230V, 125V, 110V, 48V, 24V	380/220 (two voltages)
Line Voltage Frequency	50/60 Hz	50/60 Hz
Supply Voltage Tolerance	+10/-15%	+10/-15%
Consumption	3VA	3VA
Input Circuit Test Voltage	4 kV	4 kV
Voltage Between Probes and Common	6-18 V ef.	6-18 V ef.
Max. Consumption of Probes	0.18 mA ef.	0.18 mA ef.
Max. Resistance Between Probes	200 k ohm	200 k ohm
Switch ON Response Time	1 s	1 s
Switch OFF Response Time	1 s	1 s
Repeat Accuracy with 0.85 - 1.1 Un	2%	2%
Weight	0.275, .60 lbs.	0.195, .42 lbs.
Approval & Standards	VDE 0106 EN 50001 EN 50005 EN 50011 DIN 46199 IEC 947.5.1 UNE 20119 UL508	VDE 0106 UL508 IEC 947.5.1 UNE 20119

For ambient conditions data see p. 10-45, Table 2.

Note: The relay has one LED that lights when the output contact is made.

Control Voltage

Single Voltage	Dual Voltage
Terminals 2-10	220-230 VAC (Terminals 2-10) 380-400 VAC (Terminals 2-11)

Pump-IN control wiring diagram

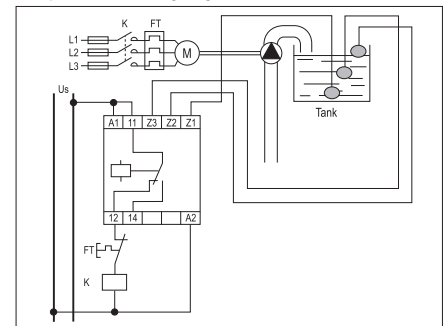

Pump-OUT control wiring diagram

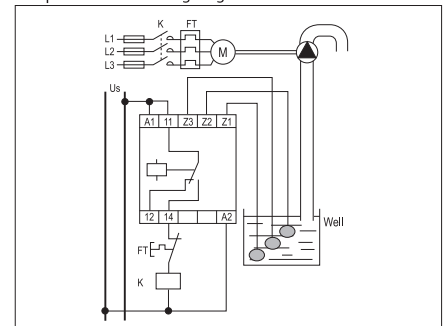

DINIL-03

Pump-IN control wiring diagram

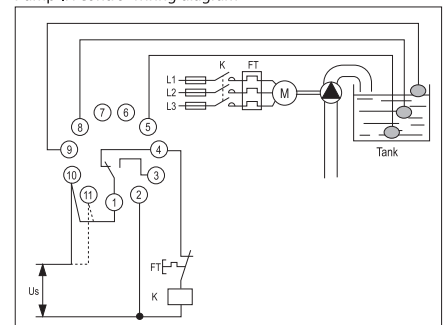

Pump-OUT control wiring diagram

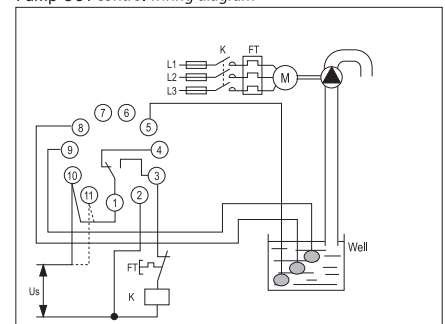

DINIL-03E



Logic Control IEC Protective Relays Technical Data

Section 10

RPDF Unbalance and Phase Failure Relays

The RPDF-electronic relay is intended for the protection of lines or electronic motors against unbalance between phases or failure of one or more phases. Detection of unbalance or phase failure is done by measuring phase change and not by voltage levels. This guarantees proper operation even when there are return paths due to motors running which are connected to the main network to be protected.

The relay is made when all conditions are normal (contact 11-14 closed); the contacts open in the event of a failure. In this way, any failure, including that of the relay supply voltage, will cause disconnection and prevent the supply from being left unprotected.

Setting unbalance

The unbalance of phases is a limiting factor in the life of an electric motor. The graph below right shows the percentage temperature increase in a three-phase motor as a function of the degree of unbalance (See standards NEMA MG 1-1433 and 34). The percent unbalance is calculated as follows:

$$\% \text{ unbalance} = \frac{\text{max. voltage deviation from average voltage}}{\text{average voltage}} \times 100$$

Tripping is adjustable between 2.5 and 10%. Consequently protection is provided for motors working closely adjusted to rated power, to others more generously sized, and even power lines. In any case adjustments should be made so that on failure of one phase, the relay will disconnect.

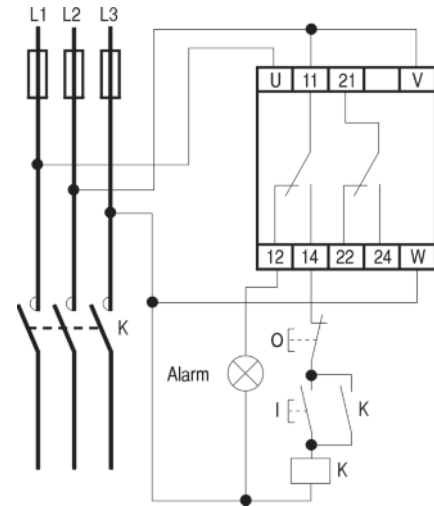

RPDF

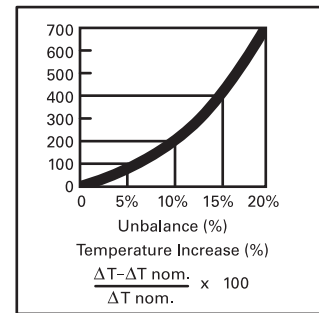

Product Number	RPDF2-50	RPDF2-60
Number of Selectable NO-NC Contacts	2	2
Output Contacts Rated Insulation Voltage: Ui AC	400V	400V
Output Contacts Rated Insulation Voltage: Ui DC	250V	250V
Output Contacts Thermal Current Ith	6A	6A
Utilization Category AC15 Rated Voltage Ue	120/240V	120/240V
Utilization Category AC15 Rated Current Ie	2.5/1.3A	2.5/1.3A
Utilization Category DC13 Rated Voltage Ue	110/220V	110/220V
Utilization Category DC13 Rated Current Ie	0.2/0.1A	0.2/0.1A
Supply Voltage: AC (with transformer) Un	500V, 440V, 380V, 240V, 220V	500V, 440V, 380V, 240V, 220V
Line Voltage Frequency	50Hz	60Hz
Supply Voltage Tolerance	+10/-20%	+10/-20%
Repeat Accuracy	2%	2%
Consumption	3 VA	3 VA
Input Circuit Test Voltage	4 kV	4 kV
Unbalance Tripping (adjustable)	2.5 to 10% Un	2.5 to 10% Un
Switch ON Response Time	100 ms	100 ms
Reset Hysteresis (% of tripping value)	2%	2%
Weight	0.250, .55 lbs.	0.250, .55 lbs.
Approval & Standards	VDE 0106 EN 50001 EN 50005 EN 50011 DIN 46199 IEC 947.5.1 UNE 20-119 UL508 ¹	VDE 0106 EN 50001 EN 50005 EN 50011 DIN 46199 IEC 947.5.1 UNE 20-119 UL508 ¹

For ambient conditions data see p. 10-45, Table 2.

¹For supply voltage less than 300V.



Logic Control IEC Protective Relays Technical Data

RSFF Phase Sequence and Phase Failure Relays

The RSFF relay is designed to detect phase sequence errors and/or phase failures in three phase lines by measuring the three phase voltage angle and amplitude. An external potentiometer is used to adjust the level of acceptable unbalance (2.5% to 10.0%).

Product Number	RSFF1-50	RSFF1-60
Number of Selectable NO-NC Contacts	1	1
Output Contacts Rated Insulation Voltage: Ui AC	400V	400V
Output Contacts Rated Insulation Voltage: Ui DC	250V	250V
Output Contacts Thermal Current Ith	6A	6A
Utilization Category AC15 Rated Voltage Ue	120/240V	120/240V
Utilization Category AC15 Rated Current Ie	2.5/1.3A	2.5/1.3A
Utilization Category DC13 Rated Voltage Ue	110/220V	110/220V
Utilization Category DC13 Rated Current Ie	0.2/0.1A	0.2/0.1A
Supply Voltage: AC (with transformer) Un	440V, 380-400V, 220-230V	380-400V, 220-230V
Line Voltage Frequency	50Hz	60Hz
Supply Voltage Tolerance	+15/-20%	+15/-20%
Repeat Accuracy	2%	2%
Consumption	3 VA	3 VA
Input Circuit Test Voltage	4 kV	4 kV
Switch ON Response Time	200 ms	200 ms
Switch OFF Response Time	1s	1s
Weight	0.230, .50 lbs.	0.230, .50 lbs.
Approval & Standards	VDE 0106, EN 50001, EN 50005, EN 50011, DIN 46199, IEC 947.5.1, UNE 20-119, UL508 ¹	VDE 0106, EN 50001, EN 50005, EN 50011, DIN 46199, IEC 947.5.1, UNE 20-119, UL508 ¹

For ambient conditions data see p. 10-45, Table 2.

Note: The relay has one LED that lights when the output contact is made.

¹For supply voltage less than 300V.

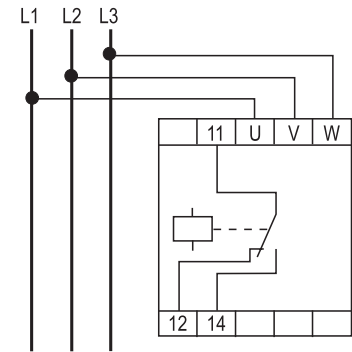

RSFF

RMM 2 Maximum and Minimum Voltage Protection (Three Phase) Relays

These voltage-sensitive relays with two selectable output contacts remain closed (contact between 11-14 or between 21-24) when voltage is within tolerance limits, and open when voltage surpasses these limits. The relays can be used to detect low or over voltage in balanced single or three-phase systems, and maximum and minimum tripping values are adjustable by means of two potentiometers.

Product Number	RMM 2
Number of Selectable NO-NC Contacts	2
Output Contacts Rated Insulation Voltage: Ui AC	400V
Output Contacts Rated Insulation Voltage: Ui DC	250V
Output Contacts Thermal Current Ith	6A
Utilization Category AC15 Rated Voltage Ue	120/240V
Utilization Category AC15 Rated Current Ie	2.5/1.3A
Utilization Category DC13 Rated Voltage Ue	110/220V
Utilization Category DC13 Rated Current Ie	0.2/0.1A
Supply Voltage: AC (with transformer) Un	500V, 440V, 400V, 380V, 240V, 220V, 125V, 110V, 24V
Supply Voltage Un: DC/AC (direct)	24V
Line Voltage Frequency	50/60 Hz
Supply Voltage Tolerance	+15/-20%
Repeat Accuracy	2%
Consumption	3 VA
Input Circuit Test Voltage	4 kV
Low Voltage Tripping (adjustable)	-5 to +20%
Overvoltage Tripping (adjustable)	+5 to +15%
Switch ON Response Time	100 ms
Reset Hysteresis (% of tripping value)	5% approx.
Weight	0.250, .55 lbs.
Approval & Standards	VDE 0106, EN 50001, EN 50005, EN 50011, DIN 46199, IEC 947.5.1, UNE 20119, UL508 ¹

For ambient conditions data see p. 10-45, Table 2.

Note: The relay has one LED that lights when the output contact is made.

¹For supply voltage less than 300V.

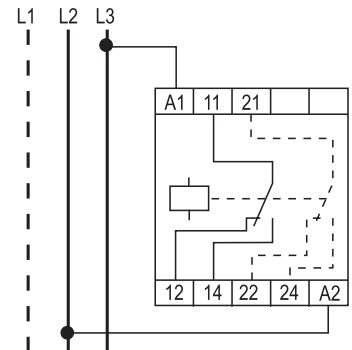

RMM 2



RS01N Thermistor Relays

This thermal probe relay is sensitive to the resistance of several thermal probes (thermistors, RTD) connected to P1 and P2 and detects overheating in motor windings, transformers, etc.

The relay disconnects when probe resistance exceeds 2500 ohms and cannot reset until resistance is lower than 1500 ohms. The absence of control voltage to the A1 and A2 terminals causes the relay to trip. When the relay trips due to motor overheating it can be reset either manually, automatically or remotely.

The RS01N detects those cases of shortcircuited probe cables (resistance lower than 20 ohms) or cut probe cables (resistance higher than 2.5 k ohms). The resistance at 77°C of the probe circuit must be within a range of 40 to 600 ohms.

Product Number	RS01N
Number of Selectable NO-NC Contacts	1
Output Contacts Rated Insulation Voltage: Ui AC	400V
Output Contacts Rated Insulation Voltage: Ui DC	250V
Output Contacts Thermal Current Ith	6A
Utilization Category AC15 Rated Voltage Ue	120/240V
Utilization Category AC15 Rated Current Ie	2.5/1.3A
Utilization Category DC13 Rated Voltage Ue	110/220V
Utilization Category DC13 Rated Current Ie	0.2/0.1A
Supply Voltage: AC (with transformer) Un	380-400, 240 220-230, 125 110, 48
Line Voltage Frequency	50/60 Hz
Supply Voltage Tolerance	+10/-15%
Repeat Accuracy	2%
Consumption	3VA
Input Circuit Test Voltage	4 kV
Switch OFF Response Time	100 ms
Hysteresis	1 k ohms
Probe Resistance min. (at 25°C)	40 Ohms
Probe Resistance max. (at 25°C)	600 Ohms
Max. Voltage in Terminals P1-P2 for R=2.5kV	< 1.6 V
Repeat Accuracy with 0.85 - 1.1 Un	2%
Weight	0.250, .55 lbs.
Approval & Standards	VDE 0106, EN 50001, EN 50005, UL508, EN 50011, DIN 46199, DIN VDE 0660-303, UNE 20119, IEC 947.5.1, IEC 34-11-2

For ambient conditions data see p. 10-45, Table 2.

Note: The relay has one LED that lights when the output contact is made.

RSR1 Adjustable Thermistor Relays

This relay has been designed for temperature control by type PT100 temperature probes.

The relay is normally ON (contacts 11-14 closed). The relay turns OFF (1) when the detected temperature exceeds the threshold value, (2) if the probe wires are cut or (3) if the control voltage is interrupted.

Product Number	RSR1...
Number of Selectable NO-NC Contacts	1
Output Contacts Rated Insulation Voltage: Ui AC	400V
Output Contacts Rated Insulation Voltage: Ui DC	250V
Output Contacts Thermal Current Ith	6A
Utilization Category AC15 Rated Voltage Ue	120/240V
Utilization Category AC15 Rated Current Ie	2.5/1.3A
Utilization Category DC13 Rated Voltage Ue	110/220V
Utilization Category DC13 Rated Current Ie	0.2/0.1A
Supply Voltage: AC (with transformer) Un	380-400V, 240V, 220-230V, 125V, 110V, 48V
Line Voltage Frequency	50/60 Hz
Supply Voltage Tolerance	+10/-15%
Repeat Accuracy	2%
Consumption	3VA
Input Circuit Test Voltage	4 kV
Switch OFF Response Time	100 ms
Hysteresis	10%
Weight	0.260, 0.57 lbs.
Approval & Standards	VDE 0106, EN 50001, EN 50005, UL508 ¹ , EN 50011, DIN 46199, UNE 20119, IEC 947.5.1

For ambient conditions data see p. 10-45, Table 2.

Note: The relay has one LED that lights when the output contact is made.

¹For supply voltage less than 300V.

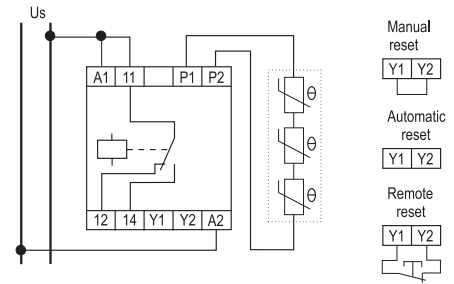

RS01N

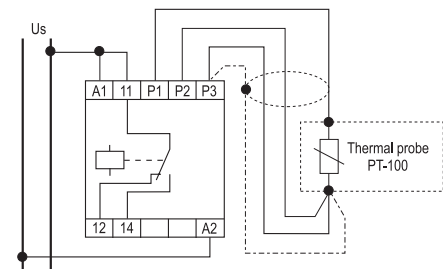

RSR1

Logic Control IEC Protective Relays Technical Data

RCF-1 Frequency Control Relays

The frequency control relay is sensitive to the frequency of the signal applied to terminals B1 and B2. The output contacts close when the frequency falls below the selected threshold (adjustable by potentiometer).

There are three frequency setting ranges: 5-15 Hz, 15-45 Hz, 45-135 Hz. Switching is independent of the input signal's amplitude being monitored at B1-B2. The signal's wave form can be sinusoidal, square, triangular, etc. This relay is suitable for suppression of rotor resistance in slip-ring asynchronous motor starters, speed reversal detector in wound rotor motors and frequency control in generating sets.

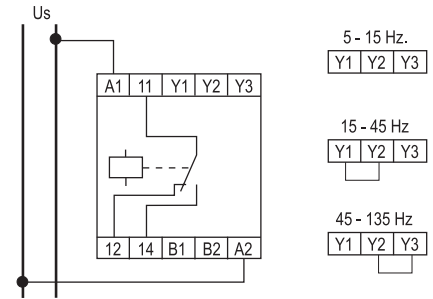

RCF-1

Product Number	RCF-1...
Number of Selectable NO-NC Contacts	1
Output Contacts Rated Insulation Voltage: Ui AC	400V
Output Contacts Rated Insulation Voltage: Ui DC	250V
Output Contacts Thermal Current Ith	6A
Utilization Category AC15 Rated Voltage Ue	120/240V
Utilization Category AC15 Rated Current Ie	2.5/1.3A
Utilization Category DC13 Rated Voltage Ue	110/220V
Utilization Category DC13 Rated Current Ie	0.2/0.1A
Supply Voltage: AC (with transformer) Un	380-400V, 240V, 220-230V, 125V, 110V, 48V, 24V
Line Voltage Frequency	50/60 Hz
Supply Voltage Tolerance	+10/-15%
Voltage between B1-B2 terminals	15V to 500V
Repeat Accuracy	2%
Consumption	3VA
Input Circuit Test Voltage	4 kV
Switch ON Response Time	100 ms
Switch OFF Response Time	800 ms
Hysteresis	1.5 Hz approx.
Repeat Accuracy with 0.85 - 1.1 Un	2%
Weight	0.280, .61 lbs.
Approval & Standards	VDE 0106, EN 50001, EN 50005, UL508 ¹ , EN 50011, DIN 46199, UNE 20119, IEC 947.5.1

For ambient conditions data see p. 10-45, Table 2.

Note: The relay has one LED that lights when the output contact is closed.

¹For supply voltage less than 300V.



Logic Control
IEC Protective Relays
Outlines and Dimensions [mm (in.)] For Estimating Only

Section 10

Page Updated 12 / 2011

Types	A
RET, RTC, RTCI, RRD, RTD, RIC, RCR, DINIL-02, DINIL-03, RSR, RCF	4 (.15)
RS01N	8 (.31)

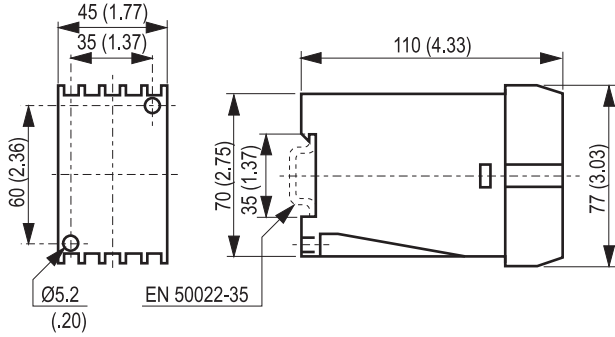

RSSF, RSF

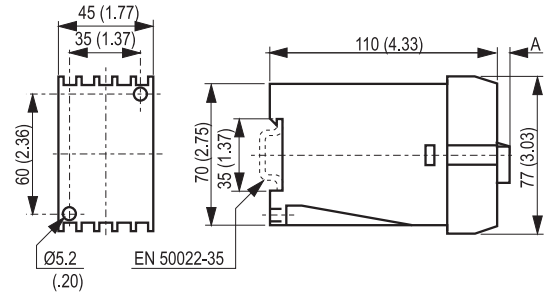

RET, RTC, RTCI, RRD, RTD, RIC, RCR, DINIL-02,
DINIL-03, RSR, RCF, RS01N

Types	A
RPDF, RMM	4 (.15)

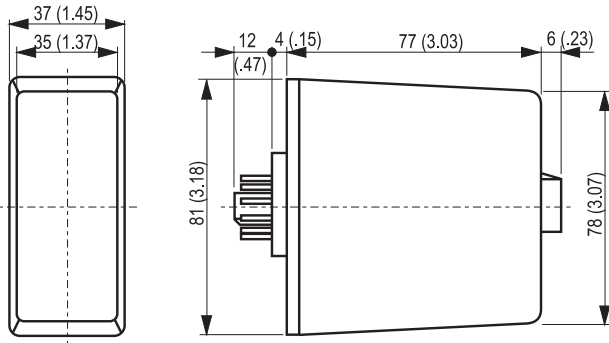

DINIL-02E, DINIL-03E

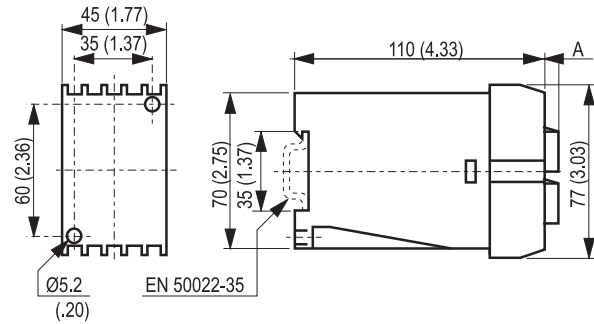

RPDF, RMM

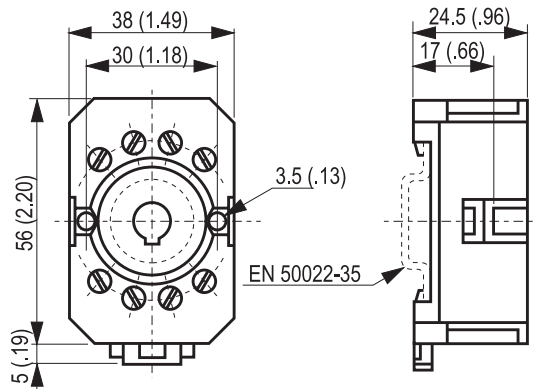

H6SZ13EFT



Logic Control IEC Protective Relays Outlines and Dimensions [mm (in.)] For Estimating Only

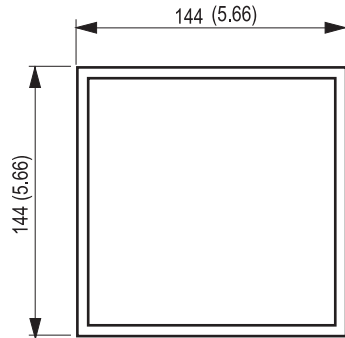

RPRB-6V

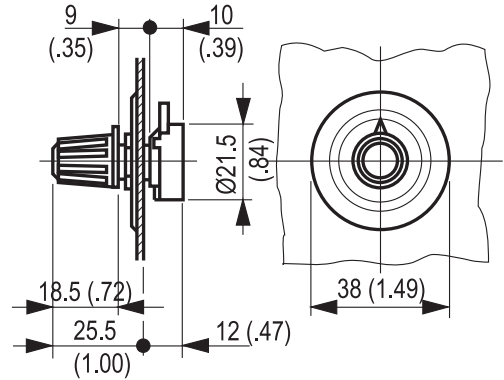
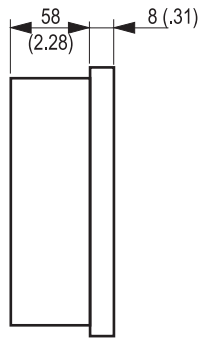

Remote Potentiometer

Differential Transformers (for use with RDH, RDHT, and RDHA Ground Fault Relays)

Type	Dimension A in. (mm)	Dimension B in. (mm)	Dimension C in. (mm)	Dimension D in. (mm)	Dimension E in. (mm)	Dimension F in. (mm)
WKA-35	35 (1.37)	75 (2.95)	99 (3.89)	42 (1.65)	92 (3.62)	33.5 (1.31)
WKA-70	70 (2.75)	98 (3.85)	132 (5.19)	60.5 (2.38)	115 (4.52)	33.5 (1.31)
WKA-105	105 (4.13)	141 (5.55)	175 (6.88)	82 (3.22)	158 (6.22)	33.5 (1.31)
WKA-140	140 (5.51)	183 (7.20)	218 (8.58)	103.5 (4.07)	200 (7.87)	33.5 (1.31)
WKA-210	210 (8.26)	270 (10.62)	309 (12.16)	150 (5.90)	290 (11.41)	43 (1.69)
WKAT-35	35 (1.37)	75 (2.95)	99 (3.89)	42 (1.65)	92 (3.62)	33.5 (1.31)
WKAT-70	70 (2.75)	98 (3.85)	132 (5.19)	60.5 (2.38)	115 (4.52)	33.5 (1.31)
WKAT-105	105 (4.13)	141 (5.55)	175 (6.88)	82 (3.22)	158 (6.22)	33.5 (1.31)
WKAT-140	140 (5.51)	183 (7.20)	218 (8.58)	103.5 (4.07)	200 (7.87)	33.5 (1.31)
WKAT-210	210 (8.26)	270 (10.62)	309 (12.16)	150 (5.90)	290 (11.41)	43 (1.69)

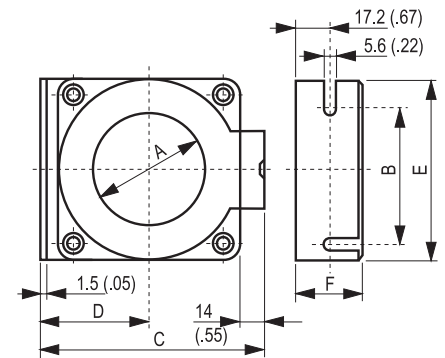

Differential Transformers

Ambient Conditions Data

Ambient Conditions Table 1

Storage Temperature	-10°C to +85°C, 14°F to 185°F
Operating Temperature	-0°C to +50°C, 32°F to 122°F
Relative Humidity	95% (without condensation)
Maximum Operating Altitude	2,000 m, 6,652 ft.
Degree of Protection	IP40 (terminals IP20)
Operating Positions	Any position

Ambient Conditions Table 2

Storage Temperature	-10°C to +85°C, 14°F to 185°F
Operating Temperature	-5°C to +50°C, 23°F to 122°F
Relative Humidity	95% (without condensation)
Maximum Operating Altitude	2,000 m, 6,652 ft.
Degree of Protection	IP40 (terminals IP20)
Operating Positions	Any position



